



# USER GUIDE & INSTALLATION INSTRUCTIONS

Classic / Professional+  
110 Dual Fuel

Australia

U110922-02



# Contents

---

<b>1. Before You Start...</b>	<b>1</b>	<b>8. Troubleshooting</b>	<b>23</b>
Personal Safety	1	<b>9. Service and Spares</b>	<b>25</b>
Electrical Connection Safety	1	<b>10. Installation</b>	<b>26</b>
If You Smell Gas	2	Provision of Ventilation	26
Peculiar Smells	2	Location of Cooker	26
Ventilation	2	Conversion	26
Maintenance	2	Positioning the Cooker	28
Oven Care	3	Moving the Cooker	29
Grill/Glide-out Grill™ Care	4	Lowering the Two Rear Rollers	29
Cooling Fan	4	Completing the Move	29
Cooker Care	4	Levelling	30
Cleaning	4	Fitting the Stability Bracket and Chain	30
<b>2. Cooker Overview</b>	<b>5</b>	Fitting the Stability Bracket	30
Hotplate Burners	5	Fitting the Restraining Chain	30
Wok Burner	6	Gas Connection	31
The Wok Cradle*	7	Pressure Testing	31
The Griddle*	7	Electrical Connection	32
The Grill	8	Fixed Wiring	33
The Ovens	9	Final Checks	34
Accessories	10	Final Fitting	34
Storage	10	Customer Care	34
Glide-out Oven Shelf ( <i>optional</i> )	11	<b>11. Conversion to LP Gas</b>	<b>35</b>
<b>3. 2 Button - rotary clock</b>	<b>12</b>	Conversion from Natural Gas (1.0 kPa) to LPG X Propane (2.54 kPa)	35
<b>4. 3 Button clock</b>	<b>15</b>	Injectors	35
<b>5. Cooking Tips</b>	<b>17</b>	Tap Adjustment	35
<b>6. Cooking Table</b>	<b>18</b>	Set the Governor	36
<b>7. Cleaning Your Cooker</b>	<b>19</b>	Pressure Testing	36
Essential information	19	Affix Label	36
Hotplate burners	19	<b>12. Servicing</b>	<b>37</b>
The Griddle	20	1. Panels	37
Glide-out Grill	20	2. Hotplate	38
Ovens	21	3. Controls	39
Cleaning table	22	4. Grill	39
		5. Ovens	40
		6. Doors	41
		<b>13. Circuit Diagram</b>	<b>43</b>
		<b>14. Technical Data</b>	<b>44</b>

---



# 1. Before You Start...

---

Your cooker should give you many years of trouble-free cooking if installed and operated correctly. It is important that you read this section before you start.

This User Guide covers a number of different models. Although some of the illustrations will look different to your particular model the functions will be the same. We hope the meaning is clear.

## Personal Safety

This appliance is for cooking purposes only. It must not be used for other purposes, for example heating a room. Using it for any other purpose could invalidate any warranty or liability claim. Besides invalidating claims this wastes fuel and may overheat the control knobs.

This cooker must be installed in accordance with the relevant instructions in this booklet and with the national and local regulations as well as the local gas and electricity supply companies' requirements.

- This appliance can be used by children aged from 8 years and above and persons with reduced physical, sensory or mental capabilities or lack of experience and knowledge if they have been given supervision or instruction concerning use of the appliance in a safe way and understand the hazards involved.
- Children **less** than 8 years of age should be kept away unless continuously supervised. Children shall not play with the appliance. Cleaning and user maintenance shall not be made by children without supervision.
- The cooker should not be placed on a base.
- This appliance is designed for domestic cooking only. Use for any other purpose could invalidate any warranty or liability claim.
- Before operating the oven(s) please refer to the oven shelf installation, in the Accessories section.
- The appliance and its accessible parts become hot during use and will retain heat even after you have stopped cooking. Care should be taken to avoid touching heating elements.
- A long term cooking process has to be supervised from time to time. A short term cooking process has to be supervised continuously.
- At the risk of fire **DO NOT** store items on the cooking surfaces.
- To avoid overheating, **DO NOT** install the cooker behind a decorative door.
- Accessible parts will become hot during use and will retain heat even after you have stopped cooking. Keep babies and children away from the cooker and never wear loose-fitting or hanging clothes when using the appliance.

- **DO NOT** use a steam cleaner on your cooker.
- Always keep combustible materials, e.g. curtains, and flammable liquids a safe distance away from the cooker.
- **DO NOT** spray aerosols in the vicinity of the cooker while it is on.

## Electrical Connection Safety

All installations must be in accordance with the relevant instructions in this booklet, with the relevant national and local regulations and with the local electricity supply companies' requirements.

### **WARNING: THE APPLIANCE MUST BE EARTHED.**

**Note:** The cooker must be connected to the correct electrical supply as stated on the voltage label on the cooker, through a suitable cooker control unit incorporating a double-pole switch, having a contact separation of at least 3 mm in all poles.

Read the instructions before installing or using this appliance

## Gas Connection Safety

- This cooker is a Class 2 Subclass 1 appliance.
- This appliance can be converted for use on another gas.
- Before installation, make sure that the cooker is suitable for your gas type and supply voltage. See the data badge.
- **DO NOT** use reconditioned or unauthorised gas controls.
- Disconnect from the electricity and gas supply before servicing.
- When servicing or replacing gas-carrying components disconnect from the gas supply before starting operation. Check the appliance is gas sound after completion.
- Make sure that the gas supply is turned on and that the cooker is wired in and switched on.
- In your own interest and that of safety, it is law that all gas appliances be installed by a qualified person(s).
- An appliance for use on LPG must not be installed in a room or internal space below ground level, e.g. in a basement.

## If You Smell Gas

- **DO NOT** turn electric switches on or off
- **DO NOT** smoke
- **DO NOT** use naked flames
- Turn off the gas at the meter or cylinder
- Open doors and windows to get rid of the gas
- Keep people away from the area affected
- Call your gas supplier

## Peculiar Smells

When you first use your cooker it may give off an odour. This should stop after use.

Before using for the first time, make sure that all packing materials have been removed and then, to dispel manufacturing odours, turn the ovens to 200 °C and run for at least an hour.

Before using the grill for the first time you should also turn on the grill and run for 30 minutes with the grill pan in position, pushed fully back and the grill door open.

Make sure the room is well ventilated to the outside air (see 'Ventilation' below). People with respiratory or allergy problems should vacate the area for this brief period.

## Ventilation

The use of a cooking appliance results in the production of heat and moisture in the room in which it is installed. Therefore, make sure that the kitchen is well ventilated: keep natural ventilation holes open or install a powered cookerhood that vents outside. If you have several hotplates/ burners on, or use the cooker for a long time, open a window or turn on an extractor fan

## Maintenance

- Only a qualified service engineer should service the appliance and only approved spare parts should be used. It is recommended that this appliance is serviced annually.
- Before removing the existing bulb, turn off the power supply and make sure that the oven and bulb have cooled.
- **DO NOT** use cooking vessels on the hotplate that overlap the edges.
- Unless specified otherwise in this guide, always allow the appliance to cool and then switch it off at the mains before cleaning or carrying out any maintenance work.
- **DO NOT** use the control knobs to manoeuvre the cooker.
- **NEVER** operate the cooker with wet hands.
- **DO NOT** use a towel or other bulky cloth in place of a glove – it might catch fire if brought into contact with a hot surface.
- **DO NOT** use hotplate protectors, foil or hotplate covers of any description. These may affect the safe use of your hotplate burners and are potentially hazardous to health.
- **NEVER** heat unopened food containers. Pressure build up may make the containers burst and cause injury.
- **DO NOT** use unstable saucepans. Always make sure that you position the handles away from the edge of the hotplate.
- **NEVER** leave the hotplate unattended at high heat settings. Pans boiling over can cause smoking, and greasy spills may catch on fire. Use a deep fat thermometer whenever possible to prevent fat overheating beyond the smoking point.
- Unattended cooking on a hob with fat or oil can be dangerous and may result in fire.
- **NEVER** leave a chip pan unattended. Always heat fat slowly, and watch as it heats. Deep fry pans should be only one third full of fat.
- **NEVER** try to move a pan of hot fat, especially a deep fat fryer. Wait until the fat is cool. Filling the pan too full of fat can cause spill over when food is added. If you use a combination of oils or fats in frying, stir them together before heating, or as the fats melt.
- Foods for frying should be as dry as possible. Frost on frozen foods or moisture on fresh foods can cause hot fat to bubble up and over the sides of the pan. Carefully watch for spills or overheating of foods when frying at high or medium high temperatures.
- **DO NOT** use the top of the flue (the slot along the back of the cooker) for warming plates, dishes, drying tea towels or softening butter.

- **DO NOT** use water on grease fires and never pick up a flaming pan. Turn the controls off and then smother a flaming pan on a surface unit by covering the pan completely with a well fitting lid or baking tray. If available, use a multi-purpose dry chemical or foam-type fire extinguisher.
- **DO NOT** modify this appliance. This appliance is not intended to be operated by means of external timer or separated remote-control system.
- If flammable materials are stored in the drawer, oven(s) or grill(s) it may explode and result in fire or property damage.

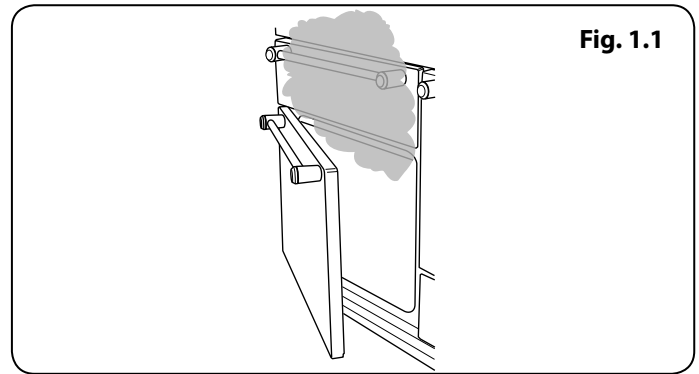

**Fig. 1.1**

## Oven Care

- When the oven is not in use and before attempting to clean the cooker always be certain that the control knobs are in the **OFF** position.
- Use oven gloves to protect your hand from potential burns.
- Cooking high moisture content foods can create a 'steam burst' when the oven door is opened (**Fig. 1.1**). When opening the oven, stand well back and allow any steam to disperse.
- The inside door face is constructed with toughened safety glass. Take care **NOT** to scratch the surface when cleaning the glass panel.
- Accidental damage may cause the door glass panel to fracture.
- Keep oven vent ducts unobstructed.
- **DO NOT** use harsh abrasive cleaners or sharp metal scrapers to clean the oven door glass since they can scratch the surface, which may result in shattering of the glass.
- Make sure the shelves are pushed firmly to the back of the oven. **DO NOT** close the door against the oven shelves.
- **DO NOT** use aluminium foil to cover shelves, linings or the oven roof.
- When the oven is on, **DO NOT** leave the oven door open for longer than necessary, otherwise the control knobs may become very hot.
- **DO NOT** use the timed oven if the adjoining oven is already warm.
- **DO NOT** place warm food in the oven to be timed.
- **DO NOT** use a timed oven that is already warm.
- Use dry oven gloves when applicable – using damp gloves might result in steam burns when you touch a hot surface.



## Grill/Glide-out Grill™ Care

- When using the grill, make sure that the grill pan is in position and pushed fully in, otherwise the control knobs may become very hot.
- **DO NOT** leave the grill on for more than a few moments without the grill pan underneath it, otherwise the knobs may become hot.
- **NEVER** close the grill door when the grill is on.
- Accessible parts may be hot when the grill is in use. Young children should be kept away.

## Cooling Fan

This appliance may have a cooling fan. When the grill or ovens are in operation the fan will run to cool the fascia and control knobs.

## Cooker Care

As steam can condense to water droplets on the cool outer trim of the oven, it may be necessary during cooking to wipe away any moisture with a soft cloth. This will also help to prevent soiling and discolouration of the oven exterior by cooking vapours.

## Cleaning

- Isolate the electricity supply before carrying out any thorough cleaning. Allow the cooker to cool.
- In the interests of hygiene and safety, the cooker should be kept clean at all times as a build up in fats and other food stuff could result in a fire.
- Clean only the parts listed in this guide.
- Clean with caution. If a wet sponge or cloth is used to wipe spills on a hot surface, be careful to avoid steam burns. Some cleaners can produce noxious fumes if applied to a hot surface.
- **NEVER** use paint solvents, washing soda, caustic cleaners, biological powders, bleach, chlorine based bleach cleaners, coarse abrasives or salt.
- **DO NOT** mix different cleaning products – they may react together with hazardous results.
- All parts of the cooker can be cleaned with hot soapy water.
- Take care that no water seeps into the appliance.
- Before you remove any of the grill parts for cleaning, make sure that they are cool or use oven gloves.
- **DO NOT** use any abrasive substances on the grill and grill parts.
- **DO NOT** put the side runners in a dishwasher.
- **DO NOT** put the burner heads in a dishwasher.
- **NEVER** use caustic or abrasive cleaners as these will damage the surface.
- **DO NOT** use steel wool, oven cleaning pads or any other materials that will scratch the surface.
- **NEVER** store flammable materials in the drawer. This includes paper, plastic and cloth items, such as cookbooks, plastic ware and towels, as well as flammable liquids.
- **DO NOT** store explosives, such as aerosol cans, on or near the appliance.
- **DO NOT** attempt to disassemble or clean around any burner while another burner is on, otherwise an electric shock could result.



## 2. Cooker Overview



Fig. 2.1

This User Guide covers a number of different models. Although some of the illustrations will look different to your particular model the functions will be the same.

The 110 dual fuel cooker (**Fig. 2.1**) has the following features:

- A. 6 hotplate burners including a wok burner
- B. A control panel
- C. A glide-out grill
- D. A (programmable) fan oven
- E. A Fan oven
- F. Storage drawer

### Hotplate Burners

The drawing by each of the central knobs indicates which burner that knob controls.

Each burner has a Flame Supervision Device (FSD) that prevents the flow of gas if the flame goes out.

**When the igniter button is pressed in, sparks will be made at every burner – this is normal. Do not attempt to disassemble or clean around any burner while another burner is on, otherwise an electric shock could result.**

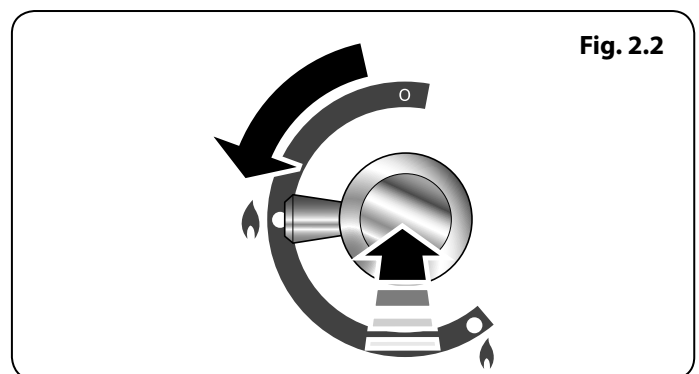
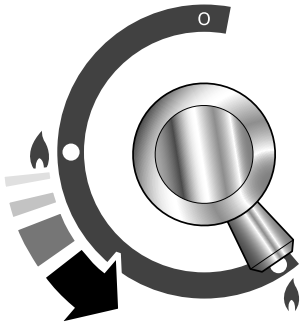

Fig. 2.2

Fig. 2.3



To light a burner, press the igniter button, and push in and turn the associated control knob to the high position as indicated by the large flame symbol (🔥), (Fig. 2.2).

The igniter should spark and light the gas. Keep holding the knob pressed in to let the gas through to the burner for about ten seconds.

If, when you let go of the control knob, the burner goes out, then the FSD has not been bypassed. Turn the control knob to the OFF position and wait for one minute before you try again, this time making sure to hold in the control knob for slightly longer.

Adjust the flame height to suit by turning the knob clockwise (Fig. 2.3).

**If a burner flame goes out, turn off the control knob and leave it for one minute before relighting it.**

Make sure that the flames are under the pans. Using a lid will help the contents boil more quickly (Fig. 2.4).

Large pans should be spaced well apart.

Pans and kettles with concave bases or down-turned base rims should not be used (Fig. 2.5).

Simmering aids, such as asbestos or mesh mats, are NOT recommended (Fig. 2.6). They will reduce burner performance and could damage the pan supports.

You should also avoid using unstable and misshapen pans that may tilt easily, and pans with a very small base diameter, e.g. milk pans, single egg poachers (Fig. 2.7).

The minimum recommended pan diameter is 120 mm. The maximum allowable pan base diameter is 260 mm.

**DO NOT** use cooking vessels on the hotplate that overlap the edges.

## Wok Burner

The wok burner is designed to provide even heat over a large area. They are ideal for large pans and stir-frying (Fig. 2.8).

For heating smaller pans, the aforementioned hotplate burners may be more efficient.

You should wipe the enamel top surface of the cooker around the hotplate burners as soon as possible after spills occur. Try to wipe them off while the enamel is still warm.

**NOTE:** The use of aluminium pans may cause metallic marking of the pan supports. This does not affect the durability of the enamel and may be cleaned off with an appropriate metal cleaner.

Fig. 2.4

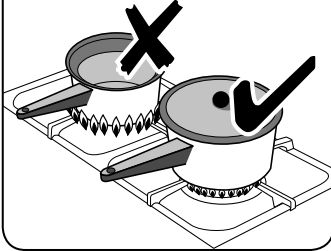

Fig. 2.5

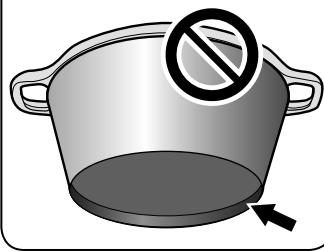

Fig. 2.6

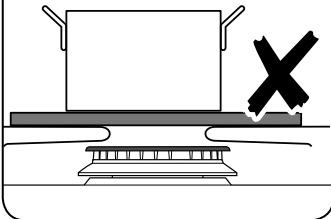

Fig. 2.7

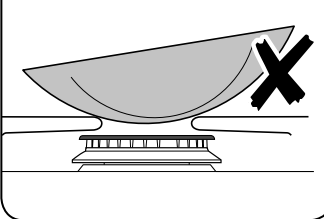
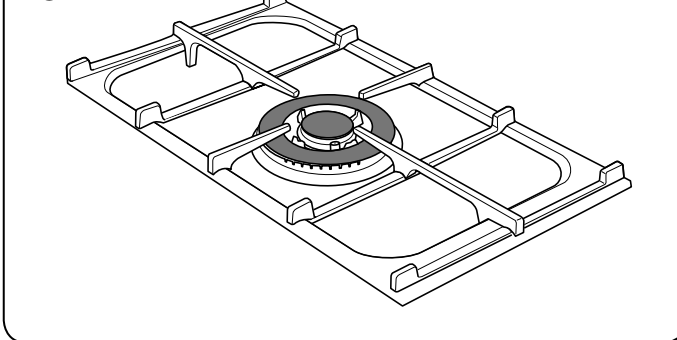

Fig. 2.8



## The Wok Cradle\*

The wok cradle is designed to fit a 35 cm wok. If you use a different wok, make sure that it fits the cradle. Woks vary very widely in size and shape. It is important that the wok sits down on the pan support – however, if the wok is too small, the cradle will not support it properly (**Fig. 2.9**).

The cradle should be used on the wok burner only. When you fit the cradle, make sure that it is supported properly on a pan support and the wok is sitting level in the cradle (**Fig. 2.10**).

The cradle will get very hot in use – allow plenty of time for it to cool before you pick it up.

## The Griddle\*

The griddle fits the left-hand pan support, front to back (**Fig. 2.11**). It is designed for cooking food on directly. **DO NOT** use pans of any kind on it. The griddle surface is non-stick and metal cooking utensils (e.g. spatulas) will damage the surface. Use heat resistant plastic or wooden utensils.

- ⚠ DO NOT put it crossways – it will not fit properly and will be unstable (Fig. 2.12).**
- ⚠ DO NOT put it on any other burner – it is not designed to fit in any of the other pan supports.**

Position the griddle over the hotplate burners resting on the pan support. Check that it is securely located.

The griddle can be lightly brushed with cooking oil before use (**Fig. 2.13**). Light the hotplate burners. Adjust the flame heights to suit.

Preheat the griddle for **a maximum of 5 minutes** before adding food. Leaving it longer may cause damage. Turn the control knobs towards the low position, marked with the small flame symbol, to reduce the burner flames.

- ⚠ Always leave space around the griddle for the gases to escape.**
- ⚠ NEVER fit two griddles side by side (Fig. 2.14).**

After cooking, allow the griddle to cool before cleaning.

*\*Supplied with selected models only.*

*Available as an optional extra.*

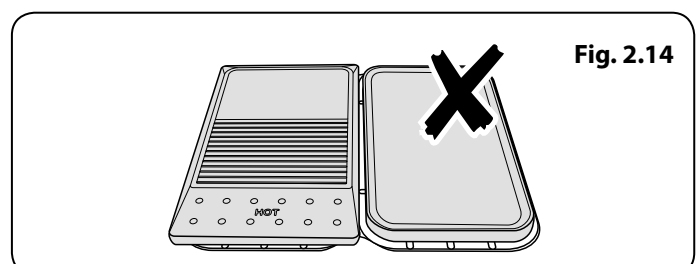
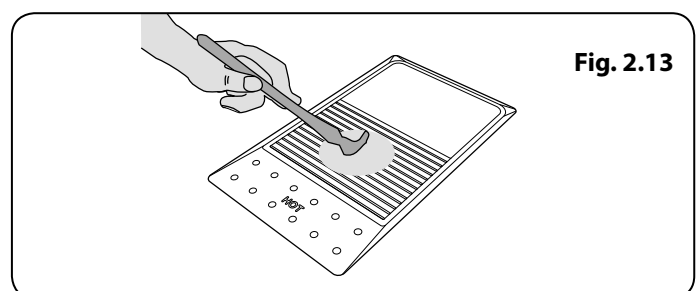
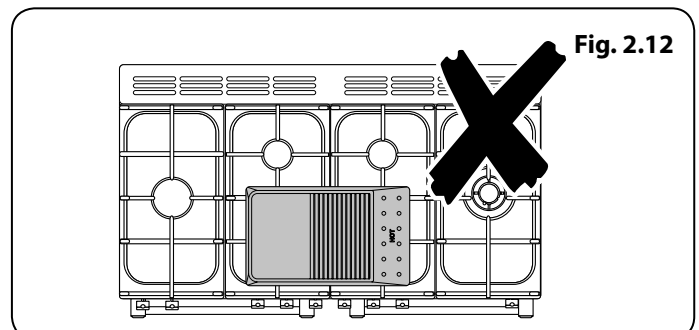
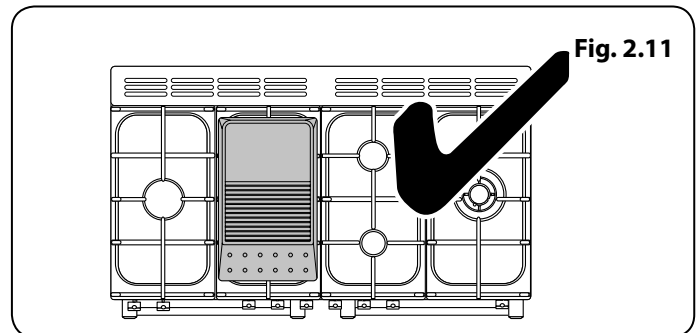
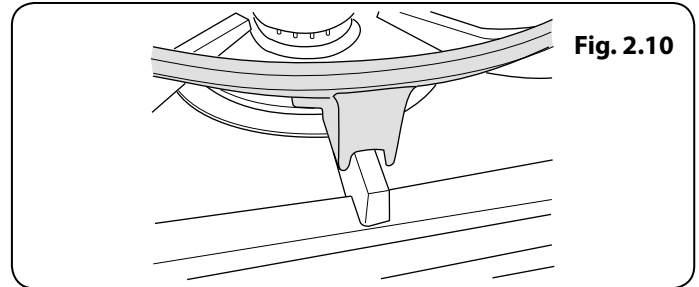
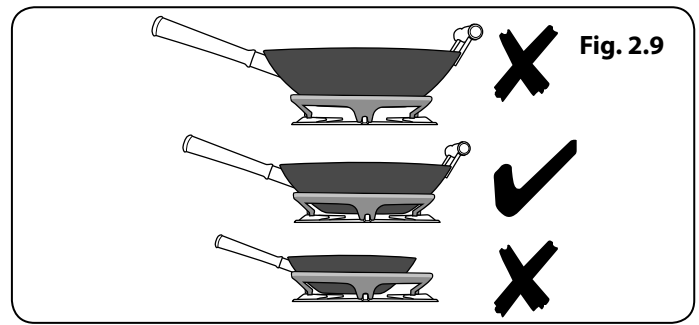

Fig. 2.15

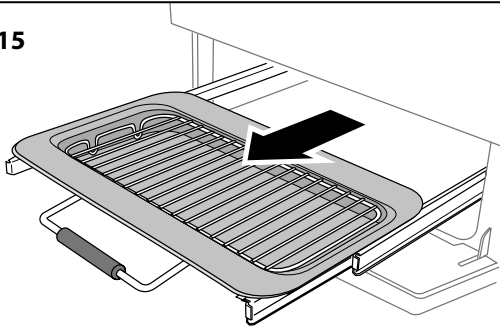

Fig. 2.16

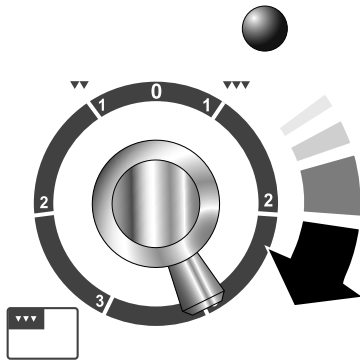
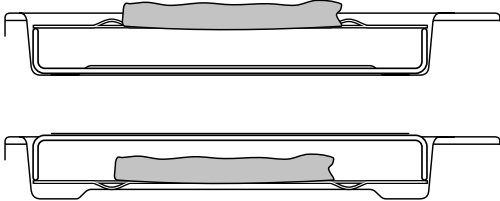

Fig. 2.17



## The Grill

**⚠ CAUTION: This appliance is for cooking purposes only. It must not be used for other purposes, for example room heating.**

**⚠ CAUTION: Accessible parts may be hot when the grill is in use. Young children should be kept away.**

Open the door and pull the grill pan forward using the handle (Fig. 2.15).

The grill has two elements that allow either the whole area of the pan to be heated or just the right-hand half.

Adjust the heat to suit by turning the control knob. To heat the whole grill, turn the control knob clockwise (Fig. 2.16). To heat the right-hand half, turn the control knob counter-clockwise.

The neon indicator light by the grill control will come on.

For best results, slide the grill pan back into the grill chamber and preheat the appropriate part(s) of the grill for two minutes. The grill trivet can be removed and the food placed on it while you are waiting for the grill to preheat.

Once the grill has preheated, slide the grill pan out again. With the trivet back in place with the food on it, slide the grill pan back into the grill chamber. Make sure that it is pushed right in.

The grill trivet can be turned over to give two grilling positions (Fig. 2.17).

**DO NOT** leave the grill on for more than a few moments, without the grill pan underneath it.

**⚠ Never close the grill door when the grill is on.**

## The Ovens

The clock must be set to the time of day before the ovens will work. See the following section on 'The Clock' for instructions on setting the time of day.

*References to 'left-hand' and 'right-hand' ovens apply as viewed from the front of the appliance.*

The left-hand oven is a programmable fan oven (**Fig. 2.18**), while the right-hand oven is a fan oven (**Fig. 2.19**).

### The Fan Oven

The right-hand oven is a fan oven that circulates hot air continuously, which means faster, more even cooking.

The recommended cooking temperatures for a fan oven are generally lower than a conventional oven.

**NOTE:** Please remember that all cookers vary so temperatures in your new ovens may differ to those in your previous cooker.

## Operating the Ovens

### Fan Ovens

Turn the oven knob to the desired temperature (**Fig. 2.20**).

The oven indicator light will glow until the oven has reached the temperature selected. It will then cycle on and off during cooking (**Fig. 2.21**).

### Main Oven Lights

Press the button to turn the lights on (**Fig. 2.22**).

If an oven light fails, turn off the power supply before changing the bulb. See the 'Troubleshooting' section for details on how to change the bulb.

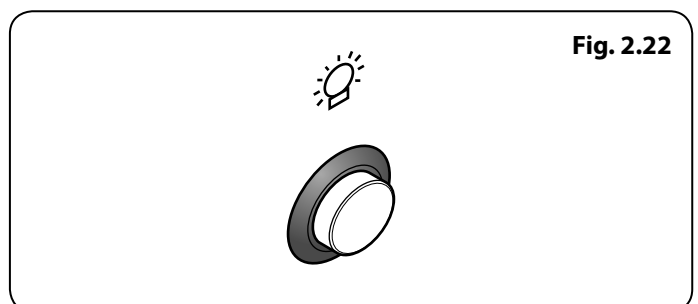
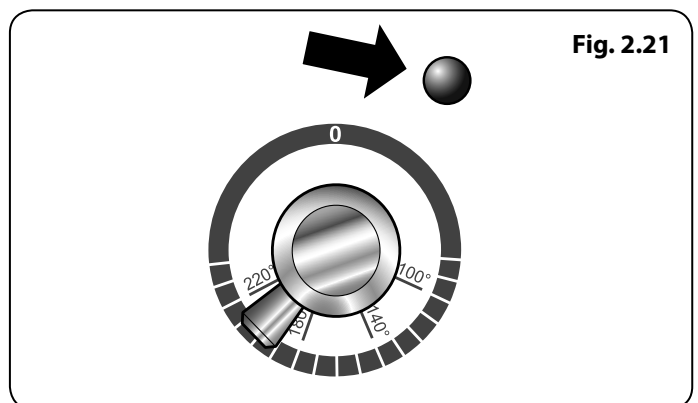
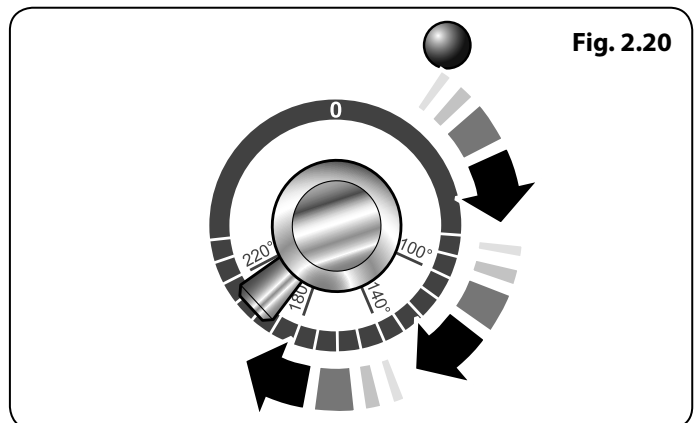
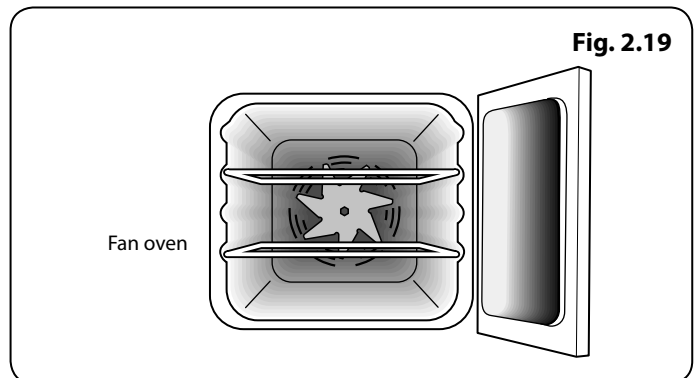
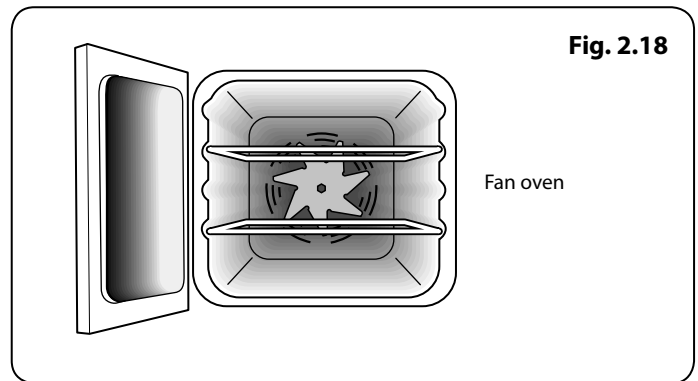

## Accessories

### Oven Shelves

The oven shelves (**Fig. 2.23**) can be easily removed and refitted.

Pull the shelf forward until the back of the shelf is stopped by the shelf stop bumps in the oven sides (**Fig. 2.24**).

Lift up the front of the shelf so the back of the shelf will pass under the shelf stop and then pull the shelf forward (**Fig. 2.25**).

To refit the shelf, line up the shelf with a groove in the oven side and push the shelf back until the ends hit the shelf stop. Lift up the front so the shelf ends clear the shelf stops, and then lower the front so that the shelf is level and push it fully back (**Fig. 2.26**).

### The Handyrack (Main Oven)

The Handyrack (**Fig. 2.27**) fits to the left-hand oven door only. Food cooking on it is easy to attend to, because it is accessible when the door is open.

The maximum weight that can be held by the Handyrack is 5.5 kg (12 lb). It should only be used with the supplied roasting tin, which is designed to fit the Handyrack. Any other vessel could be unstable.

It can be fitted at two different heights. One of the oven shelves must be removed and the other positioned to suit.

When the Handyrack is used in its highest position, other dishes can be cooked on the bottom shelf position or base of the oven.

When the Handyrack is used in its lowest position, other dishes can be cooked on the second shelf position or base of the oven.

To fit the Handyrack, locate one side of it on the door bracket (**Fig. 2.28**).

Then spring the other side out to clip it onto the other bracket (**Fig. 2.29**).

### Storage

The bottom drawer is for storing oven trays and other cooking utensils. It can get very warm, so do not store anything in it that may melt or catch fire.

The drawer can be removed completely by pulling it right out and up.

Fig. 2.23

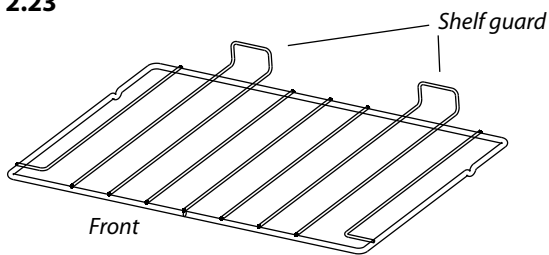

Fig. 2.24

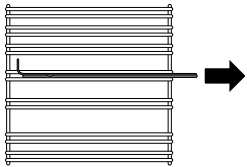

Fig. 2.25

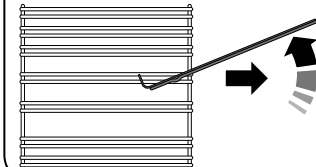

Fig. 2.26

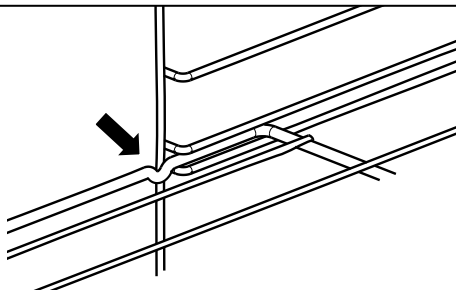

Fig. 2.27

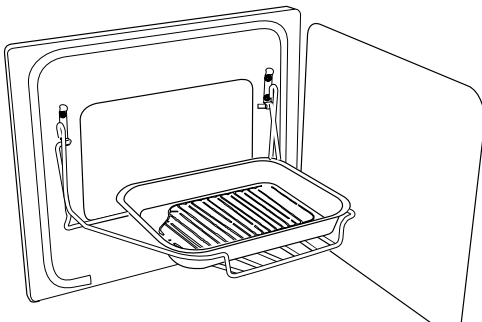

Fig. 2.28

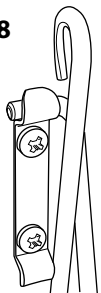
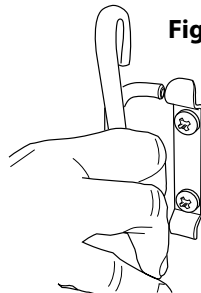

Fig. 2.29



## Glide-out Oven Shelf (optional)

A glide-out oven shelf is available for either oven (**Fig. 2.30**).

**Note:** The Handyrack must be removed before fitting the glide-out shelf.

The rungs on the shelf supports are in pairs. The glide-out shelf runners can be fitted to any pair except the top.

### To fit the glide-out shelf runners

Hook the rear of the runner over the top rung of a pair of shelf supports. Then hook the front of the runner onto the same rung. Push to clip under the bottom rung (**Fig. 2.31**).

The front of the shelf runners can be identified by the bracket (**Fig. 2.33**).

Ensure that the shelf runners are fitted in the same position on each side (**Fig. 2.32**).

### To fit the glide-out shelf

Check the shelf runners are secure before fitting the glide-out shelf.

Hook the front of the glide-out oven shelf onto the runners as shown (**Fig. 2.33**). The rear of the shelf should rest on the runners, in front of the rear stop (**Fig. 2.33**).

Ensure that the shelf sits flat once in position.

**⚠ DO NOT put the glide-out shelf runners in a dishwasher**

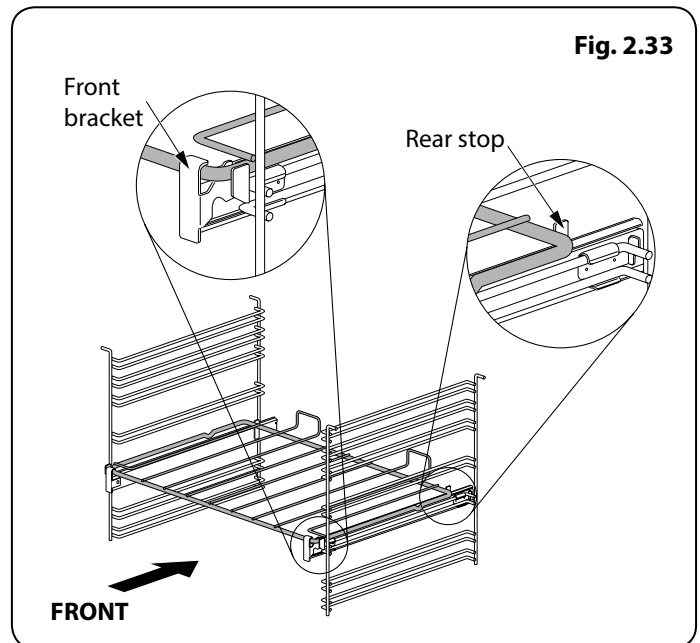
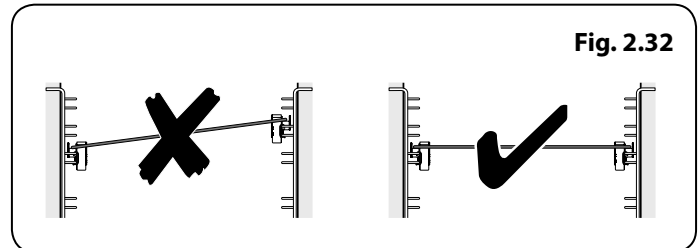
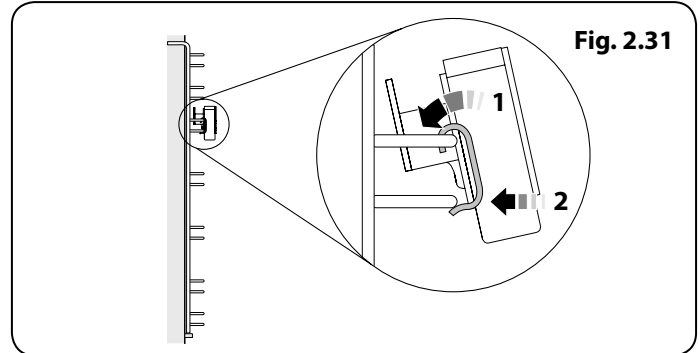
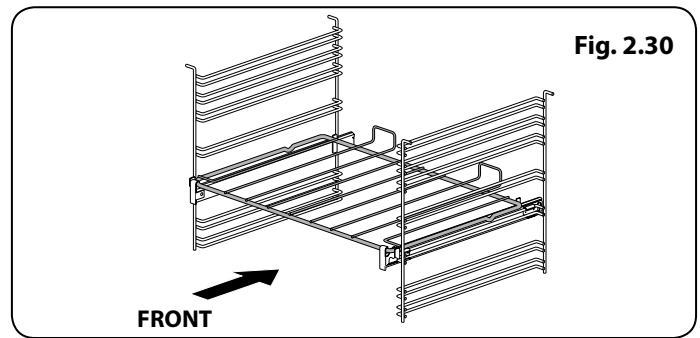



## 3. 2 Button - rotary clock

Fig. 3.1

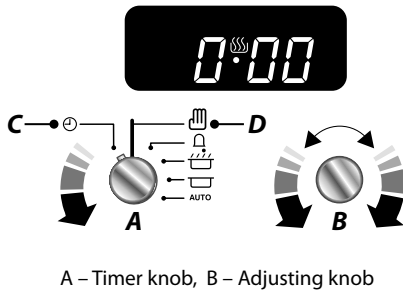

Fig. 3.2

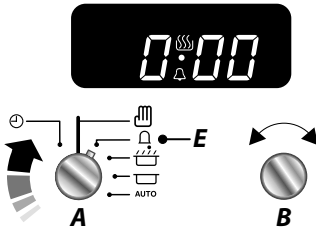

Fig. 3.3

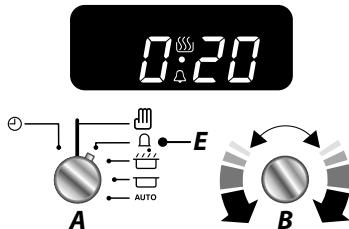
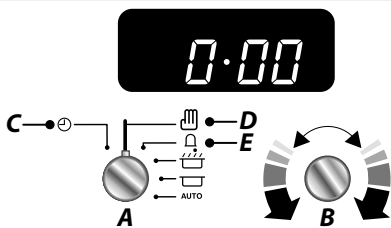

Fig. 3.4



The clock must be set to the time of day before the oven will work.

### Setting the Clock

1. Once the cooker is connected and switched on, the display will start to flash.
2. To set the time, turn the **Timer (A)** knob to the **Clock (C)** setting and back to the **Manual (D)** position. The centre dot will flash indicating the time can be set. Turn the **Adjusting (B)** knob either clockwise or counter-clockwise (**Fig. 3.1**) to set the time.
3. Once you have set the time, allow the centre dot to stop flashing, the time is now set.

### Setting the minute minder

A **Minute Minder (E)** is a feature that can be set for a number of minutes and sounds an alarm once the specified amount of time has elapsed.

1. Turn the **Timer (A)** knob to the **Minute Minder (E)** setting – it should click into position (**Fig. 3.2**).
2. Turn the **Adjusting (B)** knob to set the amount of time required. Minimum time 1 minute (**Fig. 3.3**).
3. Turn the **Timer (A)** knob back to the **Manual (D)** setting to see the current time and the 'Bell' symbol on the display.

### Cancel the timer alarm

Once the specified time has elapsed it will emit an alarm. There are two ways to cancel the alarm:

1. Turn the **Adjusting (B)** knob counter-clockwise or clockwise (**Fig. 3.4**).
2. Turn the **Timer (A)** knob to the **Clock (C)** or the **Minute Minder (E)** setting, and back to the **Manual (D)** mode, to return to normal cooking (**Fig. 3.4**).

#### NOTE

If the alarm is not manually switched off it will stop after approximately 2 minutes.

When the Minute Minder is active the clock will not dim between the hours of 10 pm and 6 am

## To stop the oven at a specific time of day

You have set the required temperature and function mode and you would like the oven to automatically stop.

### TOP TIP

Make a note of the current time so you do not forget.

1. Turn the **Timer (A)** knob to the **Stop Time (G)** setting. 'AUTO' will show in the display (**Fig. 3.5**).
2. Turn the **Adjusting (B)** knob to the amount of cooking time required. The display will show the current time plus the additional cooking time you have set (**Fig. 3.6**).
3. Turn the **Timer (A)** knob to the **Auto (H)** setting. The display will show the current time, the cooking symbol and the word 'AUTO' (**Fig. 3.7**).
4. Once the specified time has elapsed it will emit an alarm and the oven will stop working. The cook pot symbol on the display will disappear and the word 'AUTO' will flash (**Fig. 3.8**).
5. When you return, turn the **Timer (A)** knob to the **Manual (D)** setting to return to manual cooking (**Fig. 3.8**).

### TOP TIP

You can check how much time you have left, to the programmed stop time, by turning **Timer (A)** from **Auto (H)** to **Stop Time (G)** and back to **Auto (H)**.

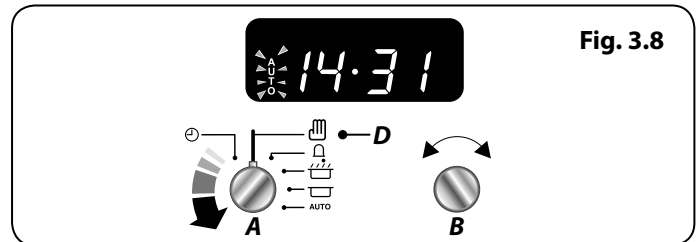
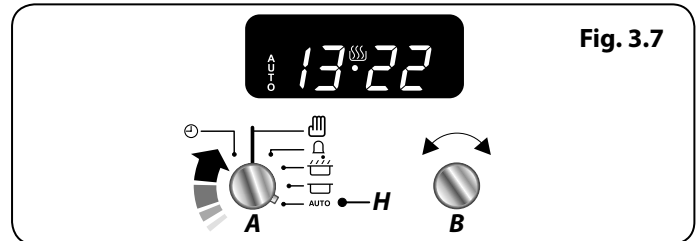
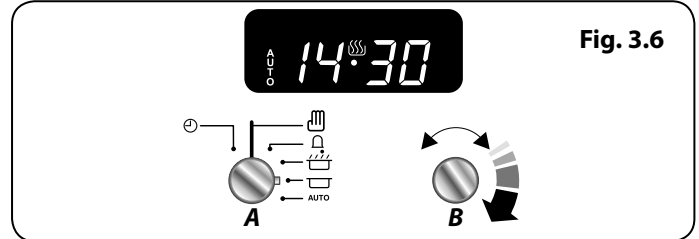
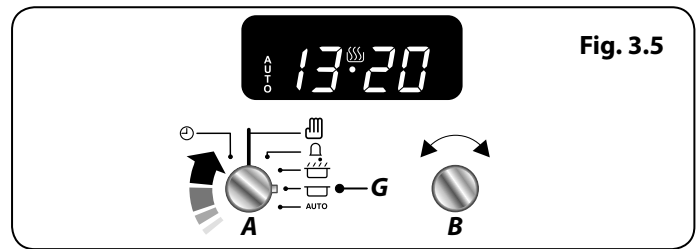

## To start and stop the oven automatically

The timer allows you to automatically start and stop by a combination of the length of the cooking time and the stop time. Giving you the flexibility to cook casseroles etc while you are out. You cannot set the actual start time.

1. Turn the **Timer (A)** knob to the **Cook Time (F)** setting. Turn the **Adjusting (B)** knob clockwise to set the length of the cooking time required (**Fig. 3.9**).
2. Turn the **Timer (A)** knob to the **Stop Time (G)** setting (**Fig. 3.10**). The display will show the current time of day plus the 'cook time' you just set.
3. Turn the **Adjusting (B)** knob to set the time of day you want the oven to stop cooking (**Fig. 3.11**).
4. Set the oven to the required cooking temperature and function mode.
5. Turn the **Timer (A)** knob to the **Auto (H)** setting (**Fig. 3.12**). If the display shows the current time and the word **'AUTO'** the oven is set to turn on and off.
6. When the program starts the oven, the cooking symbol will appear on the display. Once the specified time has elapsed it will emit an alarm and the Multifunction Oven will stop working. The 'Cooking' symbol on the display will disappear and the word **'AUTO'** will flash (**Fig. 3.13**).
7. Once the specified time has elapsed it will emit an alarm. There are two ways to cancel the alarm, refer to **"Cancel the timer alarm" on page 12**
  - The 'cook period', which is the length of time you want the oven to cook for.
  - The 'stop time', which is the time of day you want the oven to stop cooking.

## Reset to manual cooking

To cancel any automatic settings turn the **Timer (A)** knob to the **Manual (D)** setting and release (**Fig. 3.14**).

**NOTE:** Whilst this operation cancels all automatic program settings, it does not cancel the minute minder.

## Beeper tone adjustment

The beeper tone can be adjusted to three different levels.

Turn the **Timer (A)** knob to the **Clock (C)** setting. Turn the **Adjusting (B)** knob counter clockwise until the tone bars are displayed (**Fig. 3.15**).

To adjust the tone of the alarm, release the **Adjusting (B)** knob and then turn counter clockwise again (**Fig. 3.16**). The tone of the alarm will change. Repeat these steps until the desired alarm tone is set.

Fig. 3.9

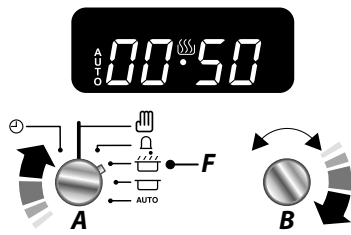

Fig. 3.10

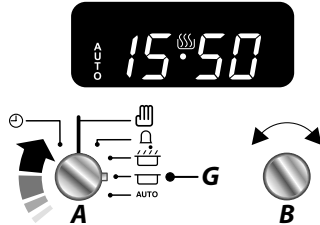

Fig. 3.11

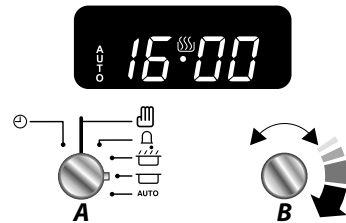

Fig. 3.12

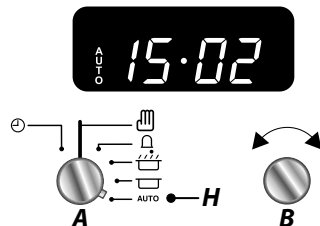

Fig. 3.13

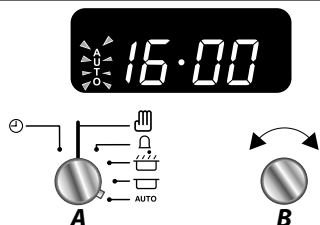

Fig. 3.14

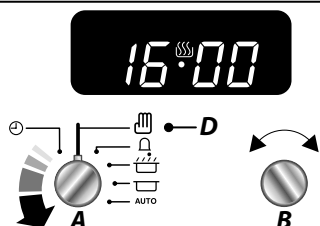

Fig. 3.15

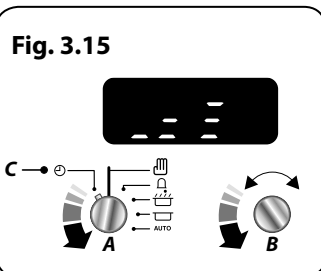
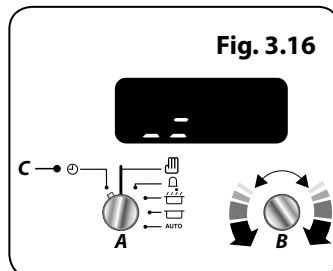

Fig. 3.16



## 4. 3 Button clock

### Using the clock

You can use the clock to turn the programmable oven on and off. **The clock must be set to the time of day before the oven will work.**

**NOTE:** When using the timer functions, first set the clock as required before setting the oven temperature.

The oven can be switched on when the cook symbol [🔥] is displayed.

### Setting the clock

1. The LCD clock is shown in **(Fig. 4.1)**. Once the cooker is connected and switched on, the display flashes (:00.00) and the time starts from (:00.00).
2. To set the clock press the [+] and [-] buttons simultaneously, the point between hours and minutes will start to flash for 5 seconds. Whilst the point is flashing press either the [+] or [-] button to set the correct time.

**IMPORTANT:** The timed oven will not operate unless the clock has been set.

### Program selection - Setting the minute minder

The minute minder [🔔] provides the ability to set a countdown from 00:01h to 23:59h, at the end of which an alarm will sound.

1. Press the mode [M] button once **(Fig. 4.2)**. The bell symbol [🔔] will flash on the display. Select the desired countdown from 00:01h to 23:59h using the [+] button **(Fig. 4.3)**. The countdown will automatically begin and the [🔔] symbol will show in the display.
2. Once the specified time has elapsed an alarm will sound.
3. To stop the alarm press any button.

### Re-set the minute minder

To re-set the minute minder, first select the minute minder program by pressing the mode [M] button. Then press the [+] and [-] buttons simultaneously.

- The 'cook period', which is the length of time you want the oven to cook for (dur).
- The 'stop time', which is the time of day you want the oven to stop cooking (End).

### To stop the programmable oven at a specific time of day

1. Press the mode [M] button 3 times, until the display flashes 'End' **(Fig. 4.4)**.
2. Select the 'stop time' using the [+] or [-] buttons. The display will show the current time along with the 'AUTO' and Cooking [🔥] symbols **(Fig. 4.5)**.

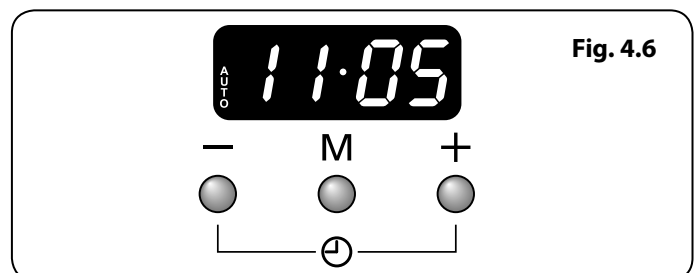
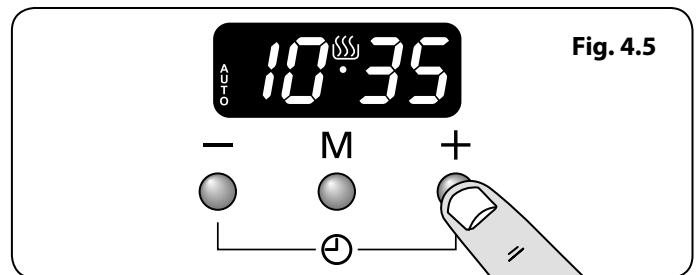
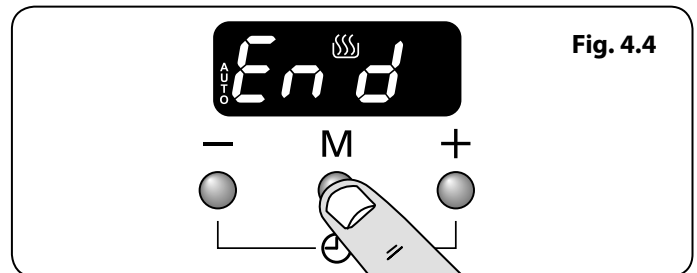
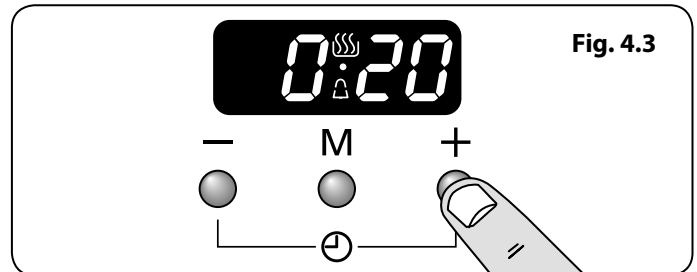
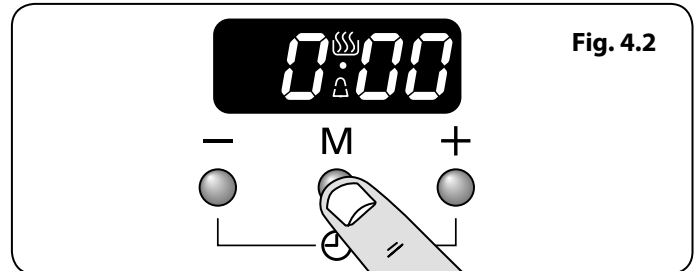
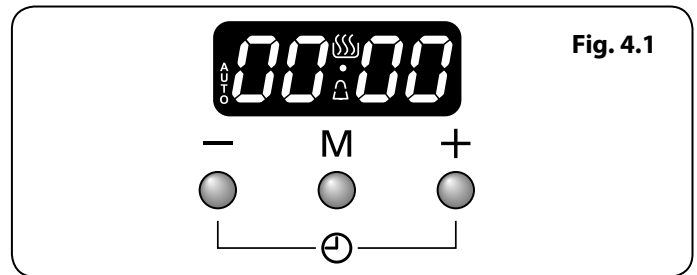

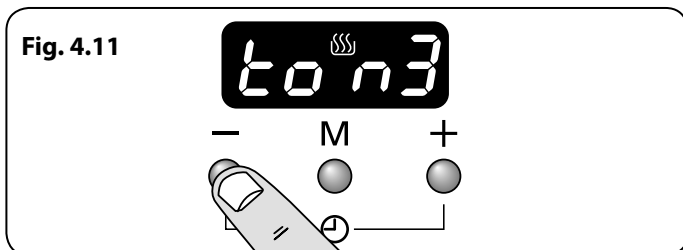
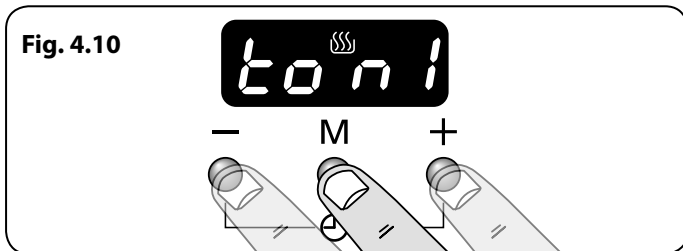
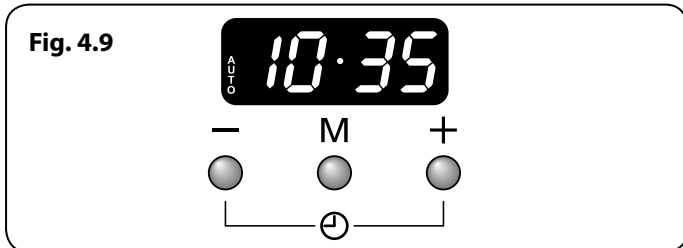
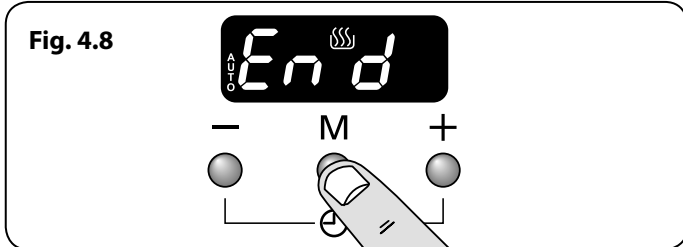
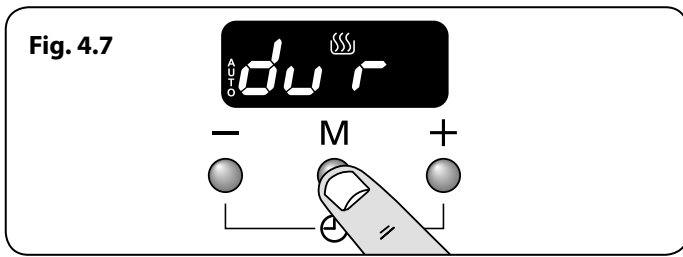

- When the 'stop time' is reached an alarm will sound and the oven will stop working. The word 'AUTO' will flash on the display (**Fig. 4.6**).
- Press any button to stop the alarm and return to manual cooking. If the alarm is not stopped, it will stop automatically after 7 minutes.

#### To start and then stop the programmable oven

Set the programmable oven to automatically start and stop using a combination of the 'cook period' and 'stop time'.

You cannot set a start time directly – this is set automatically by a combination of the 'cook period' and 'stop time'.

- Press the mode [M] button until the display flashes 'dur' (**Fig. 4.7**). Then set the 'cook period' using the [+] or [-] buttons.
- Press the mode [M] button until the display flashes 'End' (**Fig. 4.8**). Then set the 'stop time' using the [+] or [-] buttons. Current time will be displayed along with the word 'AUTO' (**Fig. 4.9**).
- Set the oven to the required cooking temperature.
- During the 'cook period' the cook symbol [🔥] is illuminated in the display.
- When cooking is finished an alarm will sound. Press any button to stop the alarm and return to manual cooking. If the alarm is not stopped, it will stop automatically after 7 minutes.

#### AUTO is showing, but you want to revert to manual cooking

You can cancel any automatic settings by pressing the [+] and [-] buttons simultaneously.

#### Changing the frequency of the alarm

It is possible to change the alarm frequency.

- Press the the [+] and [-] buttons simultaneously, then the mode [M] button. The display will show 'ton1,2 or 3' (**Fig. 4.10**).
- To select the tone press the [-] button until desired tone is reached (**Fig. 4.11**).



## 5. Cooking Tips

---

### Tips on cooking with the timer

If you want to cook more than one dish, choose dishes that require approximately the same cooking time. However, dishes can be 'slowed down' slightly by using small containers and covering them with aluminium foil, or 'speeded up' slightly by cooking smaller quantities or placing them in larger containers.

Very perishable foods such as pork or fish should be avoided if a long delay period is planned, especially in hot weather.

-  **DO NOT place warm food in the oven to be timed.**
-  **DO NOT use a timed oven that is already warm.**
-  **DO NOT use the timed oven if the adjoining oven is already warm.**

Whole poultry must be thoroughly defrosted before being placed in the oven. Check that meat and poultry are fully cooked before serving.

### General oven tips

The wire shelves should always be pushed firmly to the back of the oven.

Baking trays with food cooking on them should be placed level with the front edge of the oven's wire shelves. Other containers should be placed centrally. Keep all trays and containers away from the back of the oven, as overbrowning of the food may occur.

For even browning, the maximum recommended size of a baking tray are:

- depth: 340 mm (13 3/8") by width: 340 mm (13 3/8") in the main oven

**When the oven is on, DO NOT leave the door open for longer than necessary, otherwise the knobs may get very hot.**

- Always leave a "finger's width" between dishes on the same shelf. This allows the heat to circulate freely around them.
- To reduce fat splashing when you add vegetables to hot fat around a roast, dry them thoroughly or brush lightly with cooking oil.
- Where dishes may boil and spill over during cooking, place them on a baking tray.
- The 'Cook & Clean' oven liners (see 'Cleaning Your Cooker') work better when fat splashes are avoided. Cover meat when cooking.
- Sufficient heat rises out of the oven while cooking to warm plates in the grill compartment.
- If you want to brown the base of a pastry dish, preheat the baking tray for 15 minutes before placing the dish in the centre of the tray.

## 6. Cooking Table

The oven control settings and cooking times given in the table below are intended to be used **as a guide only**. Individual tastes may require the temperature to be altered to provide a preferred result.

Food is cooked at lower temperature in a fan oven than in a conventional oven. When using recipes, reduce the fan oven temperature by 10°C and the cooking time by 5-10 minutes. The temperature in the fan oven does not vary with height in the oven so you can use any shelf.

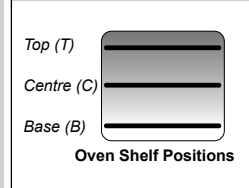

Food	Conventional Oven °C (Shelf Position)	Fan Oven Temperature	Approximate Cooking Time	
<b>Meat</b>				
Beef (no bone)	160 (C)	150 °C	30-35 minutes per 500g +30-35 minutes.	Thoroughly thaw frozen joints before cooking. Meat may be roasted at 220°C (210°C for fan oven) and the cooking time adjusted accordingly. For stuffed and rolled meats, add approximately 10 minutes per 500g, or cook at 200°C (190°C) for 20 minutes then 160°C (150°C) for the remainder.
	200 (C)	190 °C	20-25 minutes per 500g +20-25 minutes.	
Lamb	160 (C)	150 °C	30-35 minutes per 500g +30-35 minutes.	
	200 (C)	190 °C	25-30 minutes per 500g +25-30 minutes.	
Pork	160 (C)	150 °C	35-40 minutes per 500g +35-40 minutes.	
	200 (C)	190 °C	25-30 minutes per 500g +25-30 minutes.	
<b>Poultry</b>				
Chicken	160 (C)	150 °C	20-25 minutes per 500g +20-25 minutes.	For stuffed poultry, you could cook at 200°C (190°C) for 20 minutes then 160°C (150°C) for remainder. Do not forget to include the weight of the stuffing.
	200 (C)	190 °C	15-20 minutes per 500g +15-20 minutes.	
Turkey	160 (C)	150 °C	20 minutes per 500g +20 minutes.	
	200 (C)	190 °C	15 minutes per 500g +15 minutes.	
Duck	160 (C)	150 °C	25-30 minutes per 500g.	For fresh or frozen prepacked poultry, follow instructions on the pack. Thoroughly thaw frozen poultry before cooking.
	200 (C)	190 °C	20 minutes per 500g.	
Casserole	140-150 (C)	130 °C-140 °C	2-4 hours according to recipe.	
<b>Yorkshire Pudding</b>	220 (C)	210 °C	Large tins 30-35 minutes; individual 10-20 minutes.	
<b>Cake</b>				
Very rich fruit - Christmas, wedding, etc.	140 (C/B)	130 °C	45-50 minutes per 500g of mixture.	Using the conventional oven: when two tier cooking leave at least one runner space between shelves.
Fruit 180 mm tin	150 (C/B)	140 °C	2-2½ hours.	
Fruit 230 mm tin	150 (C/B)	140 °C	Up to 3½ hours.	
Madeira 180 mm	160 (C/B)	150 °C	80-90 minutes.	Position the baking tray with the front edge along the front of the oven shelf.
Queen cakes	190 (C/B)	180 °C	15-25 minutes.	
Scones	220 (C/B)	210 °C	10-15 minutes.	
Victoria sandwich				
180 mm tin	180 (C/B)	170 °C	20-30 minutes.	
210 mm tin	180 (C/B)	170 °C	30-40 minutes.	
<b>Desserts</b>				
Shortcrust tarts	200 (C/B)	190 °C	20-30 minutes on a preheated tray.	Up to three tiers can be cooked in a fan oven at the same time but make sure to leave at least one runner space between each shelf being cooked on.
Fruit pies	200 (C/B)	190 °C	35-45 minutes.	
Tartlets	200 (C/B)	190 °C	10-20 minutes according to size.	
Puff pastry	210 (C/B)	200 °C	20-40 minutes according to size.	
Meringues	100 (C/B)	90 °C	2-3 hours.	Up to three tiers can be cooked in a fan oven at the same time but make sure to leave at least one runner space between each shelf being cooked on.
Baked egg custard	160 (C/B)	150 °C	45-60 minutes.	
Baked sponge pudding	180 (C/B)	170 °C	40-45 minutes.	
Milk pudding	140-150 (C/B)	130 °C-140 °C	2 to 3 hours.	
<b>Bread</b>	210 (C)	200 °C	20-30 minutes.	
<b>Fish</b>				
Fanned Grilling				
Fillet	190 (C/B)	190 °C (C/B)	15-20 minutes	
Whole	190 (C/B)	190 °C (C/B)	15-20 minutes per 500g.	
Steak	190 (C/B)	190 °C (C/B)	Steaks according to thickness.	



## 7. Cleaning Your Cooker

### Essential information

Isolate the electricity supply before carrying out any thorough cleaning. Allow the cooker to cool.

**⚠ NEVER use paint solvents, washing soda, caustic cleaners, biological powders, bleach, chlorine based bleach cleaners, coarse abrasives or salt.**

**⚠ DO NOT mix different cleaning products – they may react together with hazardous results.**

All parts of the cooker can be cleaned with hot soapy water – **but take care that no surplus water seeps into the appliance.**

Remember to switch on the electricity supply and reset the clock before re-using the cooker.

### Hotplate burners

Some models have a separate trim ring, which fits on the burner head.

The burner heads and caps can be removed for cleaning.

**⚠ DO NOT put the burner heads in a dishwasher.**

Make sure they are absolutely dry before replacing them.

#### The Single Ring Burners

When refitting the burner head, make sure that the notch lines up with the electrode or hole in the base. Check that the burner head is level and that the cap is fitted centrally on the burner head (**Fig. 7.1**).

#### The Wok Burner

The Wok burner can also be taken apart for cleaning.

When reassembling the wok burner (**Fig. 7.2**), turn over the large base ring and find the 'D' shaped area (**Fig. 7.3**). Turn the head until the 'D' matches the one on the burner base. Flip the burner over once again and place it on the burner base.

To fit the small inner burner, find the larger electrode notch in the burner rim. Line this up with the white ignition electrode and place the inner burner on the large base ring (**Fig. 7.4**).

Now fit the two burner caps, ensuring that they are seated properly.

Check the burner ports are not blocked. If a blockage occurs, remove stubborn particles using a piece of fuse wire.

#### The Wok Cradle

Recommended cleaning materials are hot soapy water, a moistened soap pad, cream cleaner or a nylon scourer.

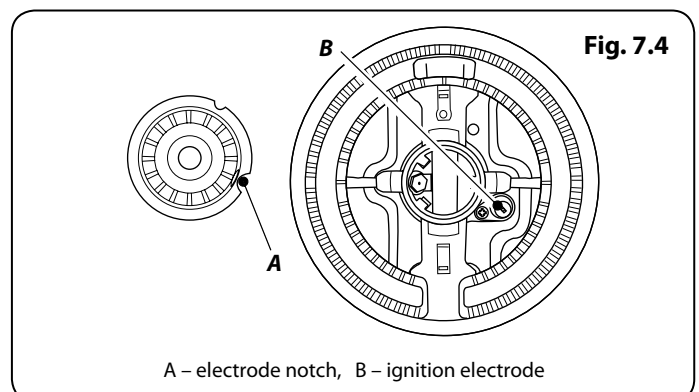
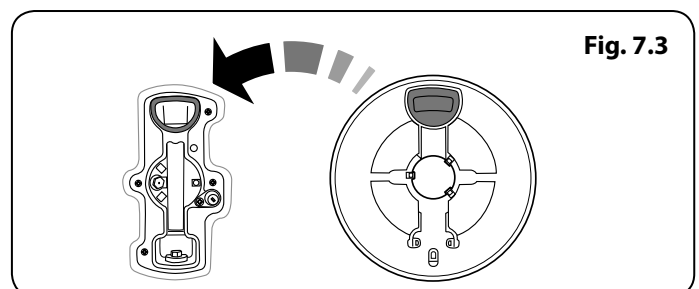
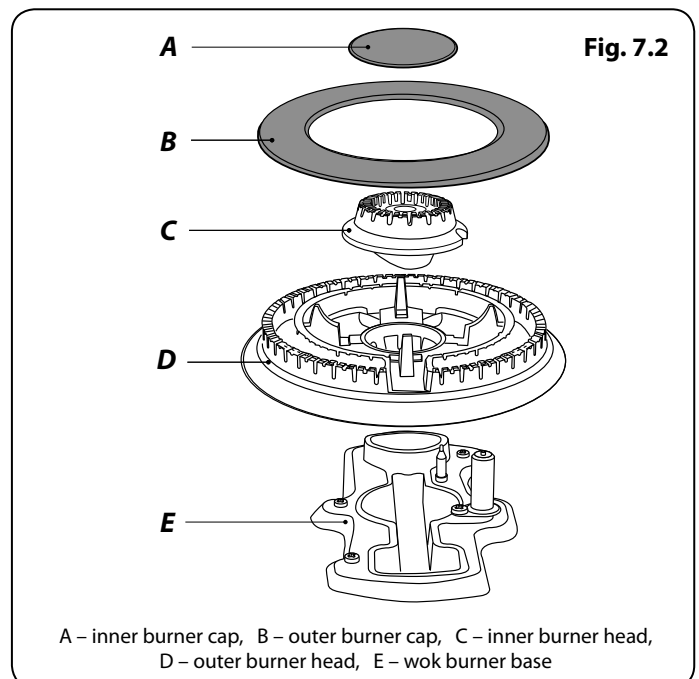
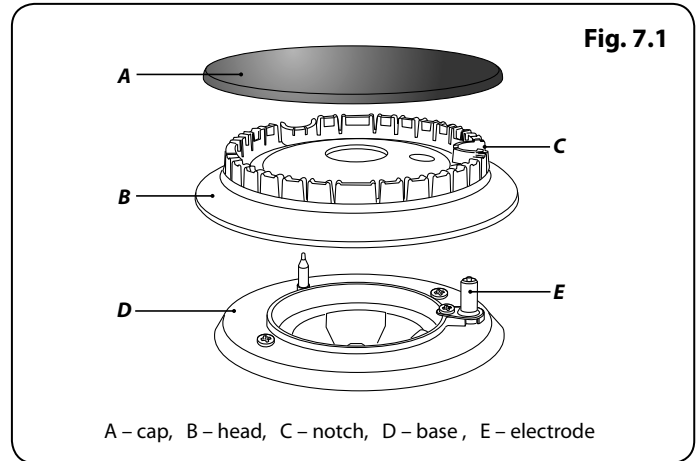

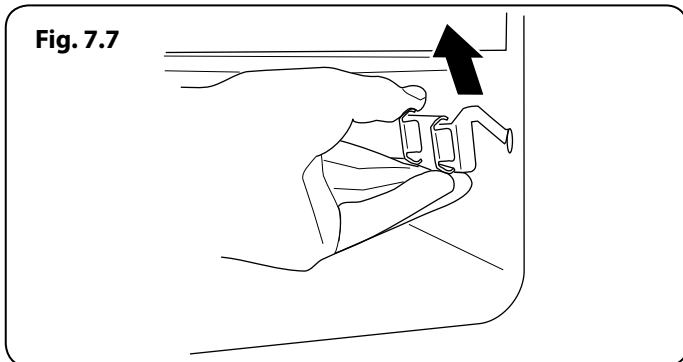
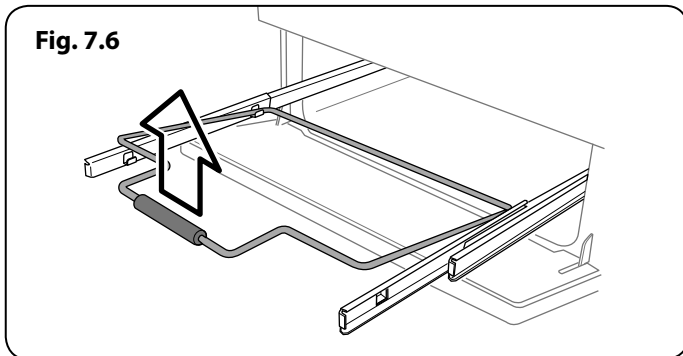
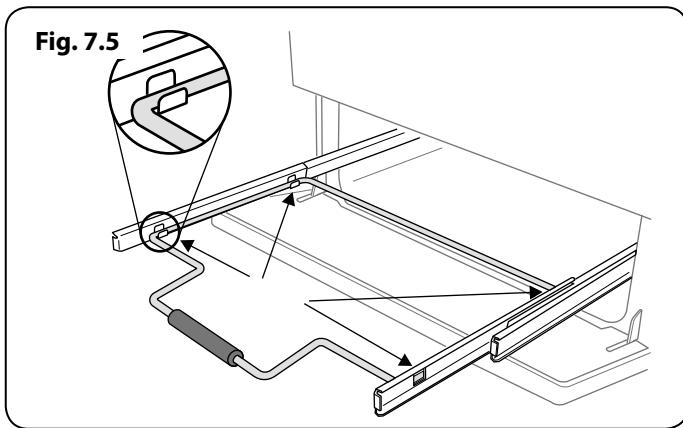

## The Griddle

Always clean the griddle after use. Allow it to cool completely before removing. Immerse the griddle plate in hot soapy water. Use a soft cloth or, for stubborn stains, a nylon washing up brush.

**NOTE:** If the griddle is washed in a dishwasher then some dishwasher residue may appear on the back. This is normal and will not affect the performance of your griddle.

## Glide-out Grill

The grill pan and trivet should be washed in hot soapy water. Alternatively, the grill pan can be washed in a dishwasher.

After grilling meats or any foods that soil, leave to soak for a few minutes in the sink immediately after use. Stubborn particles may be removed from the trivet using a nylon brush.

**⚠ Before you remove any of the grill parts for cleaning, make sure that they are cool, or use oven gloves.**

**⚠ DO NOT use any abrasive substances.**

## Cleaning the Glide-out Grill

The grill pan can be easily removed for cleaning as follows:

Remove the grill pan support frame by pulling the grill pan forward.

Lift the grill pan clear of the support frame. The support frame is held to the side rails by two clips on each side (**Fig. 7.5**).

For each side, support the side rail with one hand and with the other hand lift the frame up and out of the side clips (**Fig. 7.5**).

For safety, push the side rails back into the grill chamber.

If you need to remove the side rails to allow cleaning of the grill chamber, you can unhook them from the grill chamber sides (**Fig. 7.6**) and wipe the sides clean with a soft cloth and mild detergent.

**⚠ DO NOT put the side runners in a dishwasher.**

Once you have finished, hook the side rails back onto the sides of the chamber. To refit the frame, pull the side rails forward and, for each side in turn, support the side rail and press the frame down into the side rails. Replace the grill pan

## Control panel and doors

Avoid using any abrasive cleaners including cream cleaners, on brushed stainless steel surfaces. For best results, use a liquid detergent.

The control panel, knobs and doors should only be cleaned with a soft cloth wrung out in clean hot soapy water – but take care that no surplus water seeps into the appliance.

After cleaning, polish with a dry cloth.

## Glass fronted door panels

The oven door front panels can be taken off so that the glass panels can be cleaned. Move the cooker forward to gain access to the sides (see the 'Moving the Cooker' section under 'Installation').

Open the oven door slightly and remove the front panel fixing screws from the door sides, two each side (Fig. 7.8).

Carefully lift off the outer door panel. The inside face of the glass panels can now be cleaned – take care not to disturb or wet the door insulation.

**NOTE:** If the door is triple glazed then the inner two panels are fixed together and should not be separated.

After cleaning, carefully refit the outer door panel and replace the side fixing screws.

**⚠ DO NOT use harsh abrasive cleaners or sharp metal scrapers to clean the oven door glass since they can scratch the surface, which may result in shattering of the glass.**

## Ovens

### 'Cook & Clean' Panels

The main oven has panels which have been coated with a special enamel that partly cleans itself. This does not stop all marks on the lining, but helps to reduce the amount of manual cleaning needed.

The Cook & Clean panels work better above 200 °C. If you do most of your cooking below this temperature, occasionally remove the panels and wipe with a lint free cloth and hot soapy water. The panels should then be dried and replaced and the oven heated at 200 °C for about one hour. This will make sure that the Cook & Clean panels are working effectively.

**⚠ DO NOT use steel wool, oven cleaning pads, or any other materials that will scratch the surface.**

### Removing the main oven linings

Some of the lining panels can be removed for cleaning.

If you wish to clean the enamel interior of the oven, you will need to remove the shelves before removing the 'Cook & Clean' panels. You do not have to remove the support brackets to remove the panels. Lift each panel upward and slide forward off the support brackets (Fig. 7.9).

Once the panels have been removed, the oven enamel interior can be cleaned.

Refit in the reverse order.

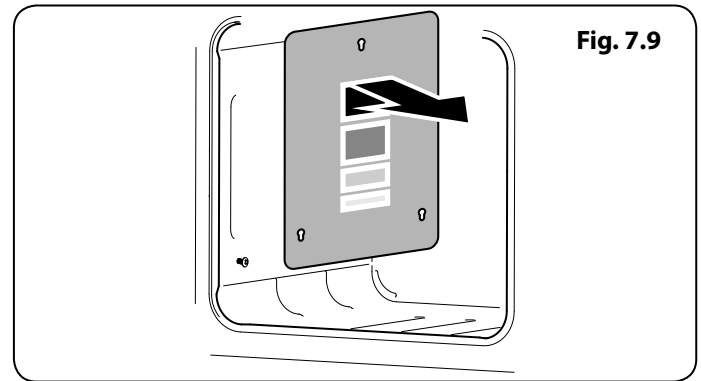
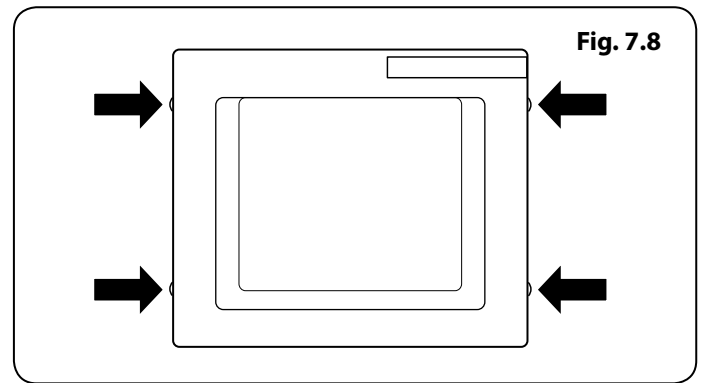

## Cleaning table

Cleaners listed are available from supermarkets or electrical retailers as stated.

For enamelled surfaces use a cleaner that is approved for use on vitreous enamel.

Regular cleaning is recommended. For easier cleaning, wipe up any spillages immediately.

<b>Hotplate</b>		
<b>Part</b>	<b>Finish</b>	<b>Recommended Cleaning Method</b>
Hob top (including burner heads and caps)	Enamel, stainless steel, aluminium	Hot soapy water, soft cloth. Any stubborn stains remove gently with a nylon scourer.
Ceramic/Induction hob	Toughened glass	Hot soapy water; cream cleaner/scourer if necessary.
Griddle plate (some models only)	Non-stick surface	Allow to cool. Wash in hot soapy water. Do not use abrasive cleaners/scourers. Dishwasher.
Warming zone (some models only)	Toughened glass	Hot soapy water, cream cleaner/scourer if necessary.
<b>Outside of Cooker</b>		
<b>Part</b>	<b>Finish</b>	<b>Recommended Cleaning Method</b>
Door, door surround and storage drawer exterior	Enamel or paint	Hot soapy water, soft cloth. Any stubborn stains, remove gently with a liquid detergent.
	Stainless steel	E-cloth (electrical retailers) or microfibre all-purpose cloth (supermarket).
Sides and plinth	Painted surface	Hot soapy water, soft cloth.
Splashback/rear grille	Enamel or stainless steel	Hot soapy water, soft cloth. Cream cleaner, with care, if necessary.
Control panel	Paint, enamel or stainless steel	Warm soapy water. Do not use abrasive cleaners on lettering.
Control knobs/handles & trims	Plastic/chrome, copper or lacquered brass	Warm soapy water, soft cloth.
	Brass	Brass polish.
Oven door glass/glass lid	Toughened glass	Hot soapy water, cream cleaner/scourer if necessary.
<b>Oven and Grill</b>		
<b>Part</b>	<b>Finish</b>	<b>Recommended Cleaning Method</b>
Sides, floor & roof of oven NOT COOK & CLEAN OVEN PANELS (see below)	Enamel	Any proprietary oven cleaner that is suitable for enamel. CAUTION: CORROSIVE/CAUSTIC OVEN CLEANERS: FOLLOW MANUFACTURER'S INSTRUCTIONS. Do not allow contact with the oven elements.
Cook & Clean oven panels (some models only)	Special enamel that partly cleans itself	This surface cleans itself at 200°C and above, or the panels can be removed and washed with hot soapy water and a nylon brush (see 'The Ovens' in 'Cleaning your Cooker').
Oven shelves, Handyrack, Grill trivet, Handygrill rack	Chrome	An oven interior cleaner that is suitable for chrome. Soap filled pad. Dishwasher.
Grill pan/meat tin (some models only)	Enamel	Hot soapy water. Soap filled pad. Dishwasher.

## 8. Troubleshooting

---

### Hotplate/Cooktop ignition or hotplate burners faulty

Is the power on? Is the clock illuminated?

If not, there maybe something wrong with the power supply.

Are the sparker (ignition electrode) or burner slots blocked by debris?

Are the burner trim and caps correctly located? See the section on 'Cleaning'.

### Hotplate/Cooktop burners will not light

Make sure that the burner parts have been replaced correctly after wiping or removing for cleaning.

Check that there is not a problem with your gas supply. You can do this by making sure that other gas appliances you may have are working.

### Do the burners spark when you push the button?

If not, verify that the power is on by checking that the clock is illuminated.

### Steam is coming from the oven

When cooking foods with high water content (e.g. oven fries) there may be some steam visible at the rear grille.

Take care when opening the oven door, as there may be a momentary puff of steam when the oven door is opened. Stand well back and allow any steam to disperse.

### What cleaning materials are recommended for the cooker?

See the 'Cleaning' section for recommended cleaning materials.

**⚠ Never use caustic or abrasive cleaners as these will damage the surface.**

### An oven fan is noisy

The note of the oven fan may change as the oven heats up – this is perfectly normal.

### If there is an installation problem and I don't get my original installer to come back to fix it who pays?

You do. Service organizations will charge for their call outs if they are correcting work carried out by your original installer. It is in your interest to track down your original installer.

### Power failure

In the event of a failure in the electrical supply, remember to reset the clock to make sure that the timed oven continues to operate.

### Food is cooking too slowly, too quickly, or burning

Cooking times may differ from your previous oven.

Check that you are using the recommended temperatures and shelf positions – see the oven cooking guide. The oven control settings and cooking times are intended to be used only as a guide.

Individual tastes may require the temperature to be altered either way, to get the results you want.

### The oven is not cooking evenly

**DO NOT** use a baking tray with dimensions larger than those specified in the section on 'General Oven Tips'.

If you are cooking a large item, be prepared to turn it round during cooking.

If two shelves are used, check that space has been left for the heat to circulate. When a baking tray is put into the oven, make sure that it is placed centrally on the shelf.

Check that the door seal is not damaged and that the door catch is adjusted so that the door is held firmly against the seal.

A dish of water when placed on the shelf should be the same depth all over. (For example, if it is deeper at the back, then the back of the cooker should be raised up or the front lowered.) If the cooker is not level, arrange for your supplier to level it for you.

### Oven not coming on

Is the power on? Is the clock illuminated? If not, there may be something wrong with the power supply.

Is the cooker supply on at the isolator switch?

Has the time of day been set?

### The timed oven is not coming on when automatic cooking

Has the oven knob been left in the OFF position by mistake?

### Oven temperature getting hotter as the cooker gets older

If turning the temperature down using the oven control knob has not worked, or has only worked for a short time, then you may need a new thermostat. This should be fitted by a qualified service person.

**Fig. 8.1**

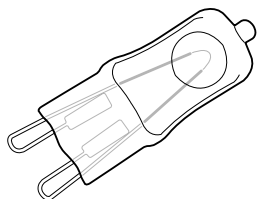

### Oven light is not working

The bulb has probably burnt out. You can buy a replacement bulb (which is not covered under the warranty) from a good electrical shop.

Ask for a 40W – 230V halogen lamp (G9) (**Fig. 8.1**).

Turn off the power at the circuit breaker.

Before removing the existing bulb, turn off the power supply and make sure that the oven and bulb have cooled. Open the oven door and remove the oven shelves.

Remove the bulb cover by turning it a quarter turn, counter-clockwise. It may be very stiff (**Fig. 8.2**).

Pull the existing bulb to remove it. When handling the replacement bulb, avoid touching the glass with your fingers, as oils from your hands can cause premature failure. Push, click in the replacement bulb.

Replace the bulb cover by turning it a quarter turn, clockwise. Turn on the circuit breaker and check that the bulb now lights.

**Fig. 8.2**

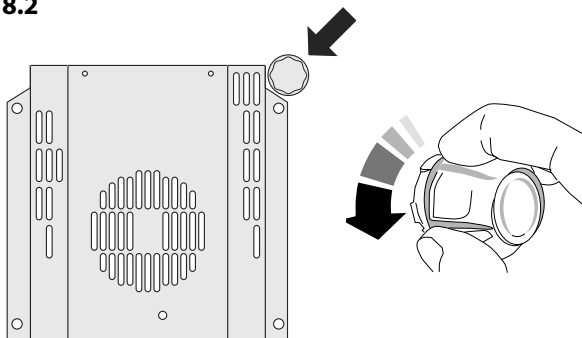

### The oven door is misaligned

The bottom hinge of either oven door can be adjusted to alter the angle of the door (**Fig. 8.3**). Loosen the bottom hinge fixing screws and use the notch and a flat bladed screwdriver to move the position of the hinge to set the hinge position (**Fig. 8.4**).

Retighten the hinge screws.

**Fig. 8.3**

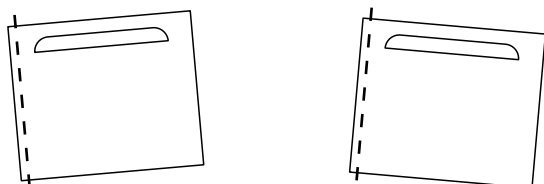

Effect of hinge adjustment – exaggerated for clarity

## Grill

### The fascia gets hot when I use the oven or grill

The cooker is cooled by a fan. If the fascia becomes excessively hot when the cooker is in use then the cooling fan may have failed. Should this occur please contact your installer, a qualified repair engineer or Customer Service to arrange for its repair.

### The knobs get hot when I use the oven or the grill. Can I avoid this?

Yes, this is caused by heat rising from the oven and heating them up. **DO NOT** leave the oven door open.

Make sure that the grill pan is pushed right back to the 'back stop' when grilling.

Always grill with the grill compartment door open.

### Grill is not cooking properly

Are you using the pan and trivet supplied with the cooker?

Is the pan being used on the runners, not the floor of the grill compartment?

Is the grill tray pushed back fully to the stop?

**Fig. 8.4**

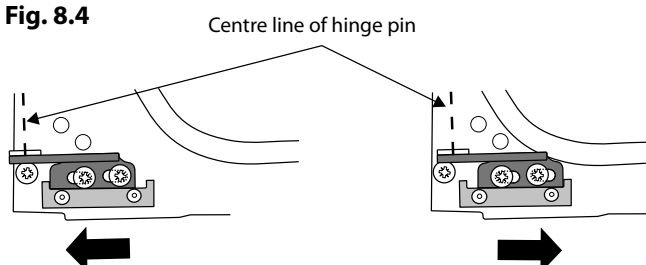

Oven door omitted for clarity

## INSTALLATION

Check the appliance is electrically safe when you have finished.

# 9. Service and Spares

Firstly, please complete the appliance details below and keep them safe for future reference – this information will enable us to accurately identify the particular appliance and help us to help you. Filling this in now will save time and inconvenience if you later have a problem with the appliance. It may also be of benefit to keep your purchase receipt with this leaflet. You may be required to produce the receipt to validate a warranty field visit.

<b>Distributor's Name and Address</b>	Andi-Co Australia Pty Ltd. 1 Stamford Road, Oakleigh, VIC 3166  Customer Care Tel: 1300 650 020 Email: service@andico.com.au
<b>Name of Appliance</b>	
<b>Appliance Serial Number*</b>	
<b>Fuel Type</b>	
<b>Date of Purchase</b>	
<b>Installer's Name, Address and Telephone No.</b>	
<b>Date of Installation</b>	

\* This information is on the appliance data badge.

## If You Have a Problem

In the unlikely event that you have a problem with your appliance, please refer to rest of this booklet, especially the problem solving section, first to check that you are using the appliance correctly.

If you are still having difficulty, contact Customer Care on 1300 650 020 or email service@andico.com.au.

## Please Note

For warranty information and how to request a remedy, please refer to the Warranty Statement at [www.andico.com.au/customer-care/falcon](http://www.andico.com.au/customer-care/falcon) or contact Customer Care.

## Out of Warranty

We recommend that our appliances are serviced regularly throughout their life to maintain the best performance and efficiency. The frequency of service will depend on usage – for normal usage once a year should suffice.

Service work should only be carried out by a suitably Authorised Person.

## Spare Parts

To maintain optimum and safe performance, we recommend that only genuine spare parts are used. Do not use re-conditioned or unauthorised controls. Contact Spare Parts on (03) 9569 7744 or email spares@andico.com.au



## INSTALLATION

Check the appliance is electrically safe and gas sound when you have finished.

# 10. Installation

## Safety Requirements and Regulations

**⚠ Please read the Before you start... chapter, before you begin any installation and maintenance work on this appliance.**

You must be aware of the following safety requirements & regulations.

**⚠ Before installation, make sure that the local distribution conditions (nature of the gas and gas pressure) and the adjustment of the appliance are compatible.**

**⚠ The appliance must be installed in accordance with the regulations in force and only in a well ventilated space.**

**⚠ Read the instructions before installing or using this appliance.**

The regulations and standards are as follows:

- AS/NZS 5601 – 'Gas Installations'
- AS/NZS 3000 - 'Wiring Rules'

In your own interest and that of safety, it is law that all gas appliances be installed by competent persons.

**⚠ Failure to install the appliance correctly could invalidate any warranty or liability claims and lead to prosecution.**

The cooker must be installed in accordance with all local gas fitting regulations, municipal building codes, electrical wiring regulations and any other relevant statutory regulations.

**⚠ WARNING!**  
**Where this appliance is installed in a marine craft, caravan or mobile home, it shall NOT be used as a space heater.**

## Provision of Ventilation

This appliance is not connected to a combustion products evacuation device. Particular attention shall be given to the relevant requirements regarding ventilation.

The room containing the cooker should have an adequate air supply.

Install the cooker in a location to allow the complete combustion of gas, proper flueing and to maintain ambient temperature of the immediate surroundings at safe limits, under normal condition.

## Location of Cooker

The cooker may be installed in a kitchen/kitchen diner but NOT in a room containing a bath or shower.

Note: An appliance for use on LPG must not be installed in a room or internal space below ground level, e.g. in a basement.

## Conversion

All models are supplied set for use on Natural gas. A conversion kit for Propane gas is included with the appliance. See the instructions that are supplied with the conversion kit.

After converting the appliance, please attach the Gas Conversion sticker over the appropriate area of the data badge – this will identify the gas type for which the appliance is now set.

## INSTALLATION

Check the appliance is electrically safe and gas sound when you have finished.

You will need the following equipment to complete the cooker installation satisfactorily:

- Flexible gas hose.
- Gas pressure tester/manometer.
- Multimeter: For electrical checks.

You will also need the following tools:

1. Electric drill
2. Masonry drill bit (only required if fitting the cooker on a stone or concrete floor)
3. Wall plugs (only required if fitting the cooker on a stone or concrete floor)
4. Steel tape measure
5. Cross head screwdriver
6. Flat head screwdriver
7. 4 mm & 3 mm Allen keys
8. Spirit level
9. Pencil
10. Adjustable spanner
11. 13 mm spanner or socket wrench
12. Screws for fitting the restraining chain and bracket

Checking the Parts:

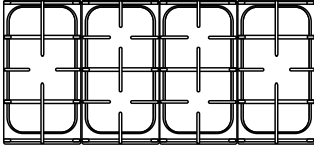
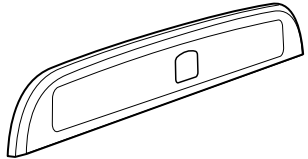
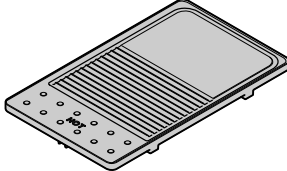
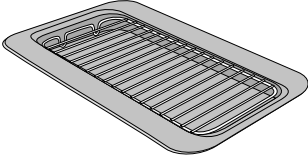
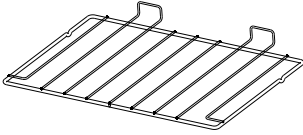
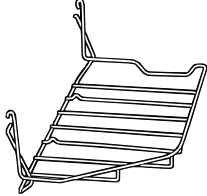
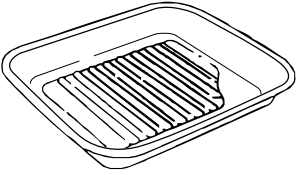
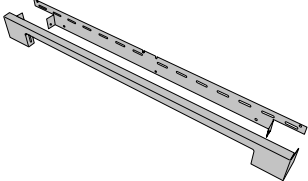
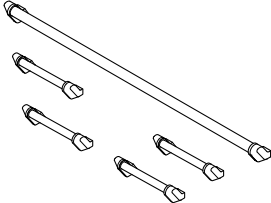
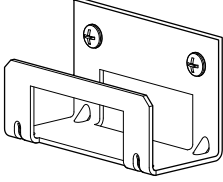
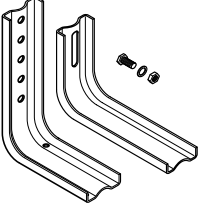
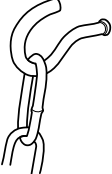
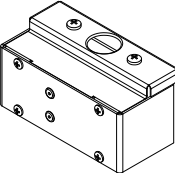
4 pan supports	Splashback (Classic only)
	
Griddle plate	Grill pan & trivet
	
Flat shelves	Handyrack
	
Roasting tin	Plinth (2-piece model shown)
	
Handles	Stability location bracket
	
Stability bracket	Restraining chain & hook
	
Conduit box	
	

## INSTALLATION

Check the appliance is electrically safe and gas sound when you have finished.

### Positioning the Cooker

The diagram (**Fig. 10.2**) shows the minimum recommended distance from the cooker to nearby surfaces as given in AS/NZS 5601.

Where the appliance is installed next to cabinetry, the cabinet material must be capable of withstanding 70°C. If this appliance is installed near vinyl wrapped surfaces, use an installation kit available from the vinyl-wrap supplier. Falcon cannot accept any responsibility for damage caused due to installation into cabinets with low temperature tolerances.

\*Any splashback must be fitted in accordance with the manufacturers instructions. Allowance should be made for the additional height of the flue trim, which is fitted to the cooker hob.

#### 1. Overhead – Measurement A

The minimum height of any surface above the cooker is 650 mm above the hotplate.

Cookerhoods and exhaust fans shall be installed in accordance with the manufacturer's instructions. However, in no case shall the clearance between the highest part of the hob of the cooking appliance and a cookerhood be less than 650 mm or, for an overhead exhaust fan, 750 mm.

#### 2. Side Clearances – Measurements B & C

Where **B**, measured from the periphery of the nearest burner to any vertical combustible surface, or vertical combustible surface covered with toughened glass or sheet metal, is less than 200 mm, the surface shall be protected to make sure that the combustible surface does not exceed 65°C above ambient\*. Even with the surface protected, the dimension **B** should not be less than 135 mm above hotplate level.

\*The fixing of 5 mm thick ceramic tiles to the surface, or attaching fire resistant material to the surface and covering with sheet metal with a minimum thickness of 0.4 mm to a height **C** of not less than 150 mm above the hotplate, should satisfy this requirement.

#### 3. Side Clearances – Measurement D & E

Where **D**, the distance from the periphery of the nearest burner to a horizontal combustible surface is less than 200 mm, then **E** shall be 10 mm or more, or the horizontal surface shall be above the trivet.

A clearance of 130 mm is required if the cooker is near a corner of the kitchen, to allow the oven doors to open. The actual opening of the doors is slightly less, but this allows for some protection of your hand as you open the door (**Fig. 10.3**).

We recommend a gap of 1110 mm between units to allow for moving the cooker. Do not box the cooker in it must still be possible to move the cooker in and out for cleaning and servicing.

Fig. 10.2

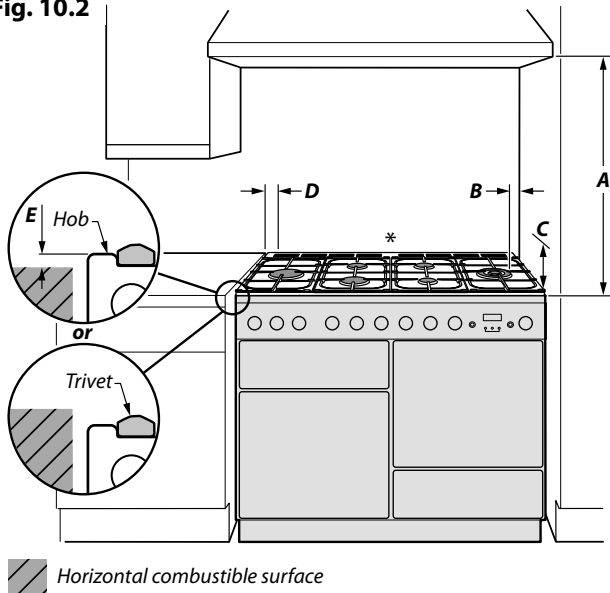
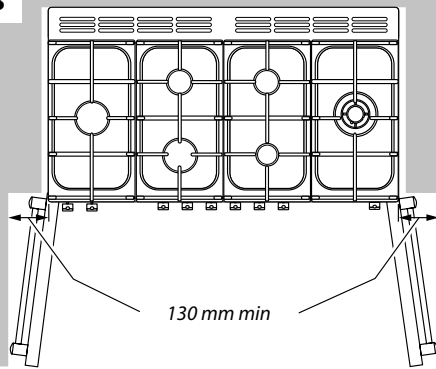

Fig. 10.3



## INSTALLATION

Check the appliance is electrically safe and gas sound when you have finished.

### Moving the Cooker

**⚠ On no account try and move the cooker while it is plugged into the electricity supply.**

**⚠ The cooker is very heavy, so take great care.**

We recommend that two people manoeuvre the cooker. Make sure that the floor covering is firmly fixed, or removed, to prevent it being disturbed when moving the cooker around.

To help you, there are two levelling rollers at the back, and two screw-down levelling feet at the front.

Remove the polystyrene base pack. From the front, tilt the cooker backwards and remove the front half of the polystyrene base (**Fig. 10.4**). Repeat from the back and remove the rear half of the polystyrene base.

### Lowering the Two Rear Rollers

To adjust the height of the rear of the cooker, first fit a 13 mm spanner or socket wrench onto the hexagonal adjusting nut (**Fig. 10.5**). Rotate the nut – clockwise to raise – counter-clockwise to lower.

Make 10 complete (360°) turns clockwise.

Make sure you lower BOTH REAR ROLLERS.

### Completing the Move

Unfold the rear edge of the cardboard base tray. Open the grill door and right-hand oven door so that you can get a good grip on the bottom of the fascia panel as you move the oven (**Fig. 10.6**).

Carefully push the cooker backwards off the base tray. Remove the base tray.

Position the cooker close to its final position, leaving just enough space to get behind it.

**⚠ Do not use the door handles or control knobs to manoeuvre the cooker.**

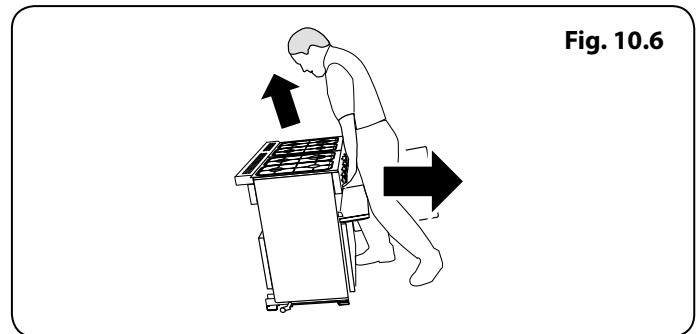
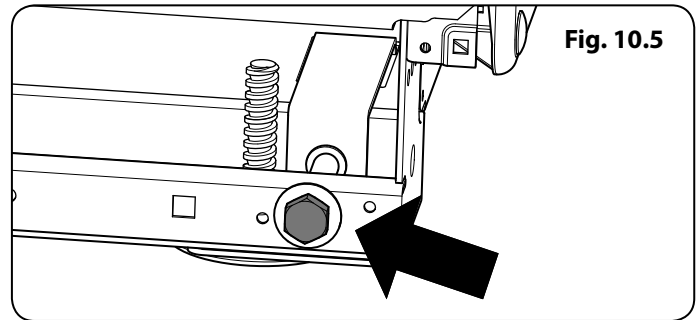
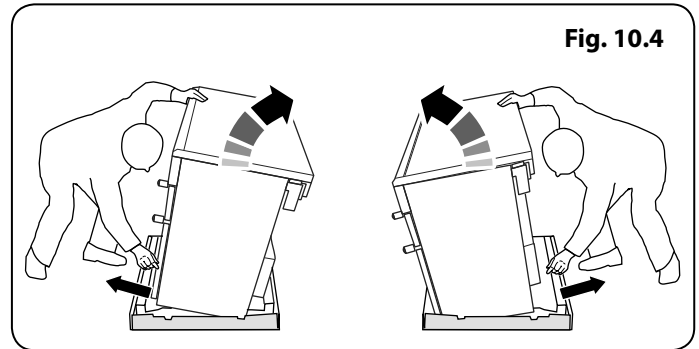

## INSTALLATION

Check the appliance is electrically safe and gas sound when you have finished.

Fig. 10.7

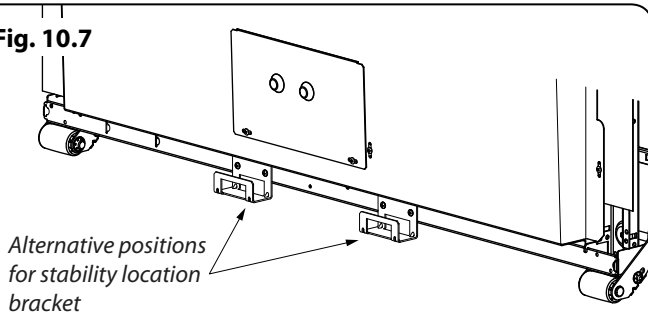

Fig. 10.8

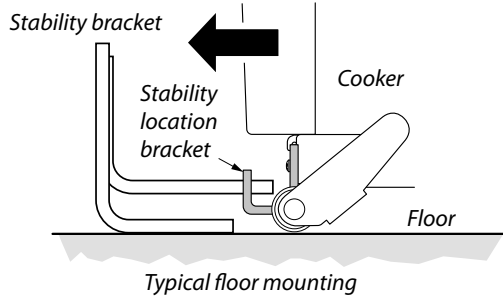

Fig. 10.9

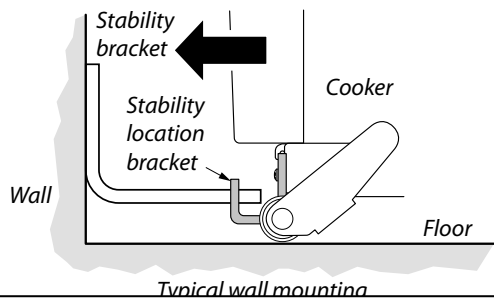
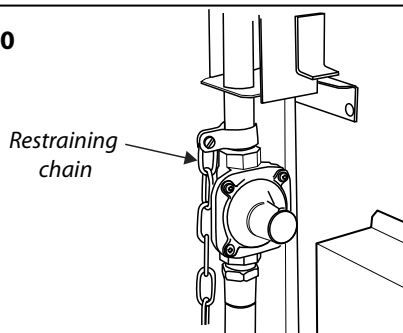

Fig. 10.10



## Levelling

You are recommended to use a spirit level on a shelf in one of the ovens to check for level.

Place the cooker in its intended position taking care not to twist it within the gap between the kitchen units as damage may occur to the cooker or the units.

The front feet and rear rollers can be adjusted to level the cooker.

To adjust the height of the rear of the cooker use a 13 mm spanner or socket wrench to turn the adjusting nuts at the front bottom corners of the cooker.

To set the front, turn the feet bases to raise or lower.

## Fitting the Stability Bracket and Chain

**▲ A stability bracket and chain MUST be fitted when the cooker is connected to a flexible gas supply.**

Unless properly installed, the cooker could be tipped by leaning on the door. Injury might result from spilled hot liquids or from the cooker itself.

**IMPORTANT:** The cooker must be set to the correct height and levelled before the stability bracket is installed.

## Fitting the Stability Bracket

When fitting the stability bracket; first attach the bracket location device to the rear of the cooker (**Fig. 10.7**). Then adjust the bracket to engage through the slot of the device (**Fig. 10.8** and **Fig. 10.9**).

## Fitting the Restraining Chain

The restraining chain **MUST** be fitted.

The length of chain between the appliance and the wall fixing should prevent strain on the gas and electricity connections, but still allow access to unhook the chain when the cooker is pull forward.

Measure the length of chain required. Use the clamp supplied to clamp onto the gas pipe (**Fig. 10.10**). Fix the supplied hook securely to the wall.

## INSTALLATION

Check the appliance is electrically safe and gas sound when you have finished.

### Gas Connection

Must be in accordance with the relevant standards.

The gas supply needs to terminate with a side-facing threaded fitting  $\frac{1}{2}$ " connection (**Fig. 10.11**).

The inlet connector is located just below the hotplate level at the rear of the cooker.

Because the height of the cooker can be adjusted and each connection is different it is difficult to give precise dimensions. Ideally, the house supply connection should be in the shaded area 'A' (**Fig. 10.12**).

Means of isolation must be provided at the supply point by either an approved quick-connect device or a Type 1 manual shut-off valve.

The hose should be fitted so that both inlet and outlet connections are vertical so that the hose hangs downwards in a 'U' shape (**Fig. 10.12**).

A flexible connection is supplied with the cooker. If it is necessary to use another hose it must be to AS 1869 Class B and be suitable for your gas type.

If in doubt contact your supplier. Screw connect the threaded end of the hose into the gas inlet.

After completing the gas connection, check the cooker is gas sound with a pressure test. When checking for gas leaks do not use washing up liquid – this can corrode. Use a product specifically manufactured for leak detection.

### Natural Gas

The adjustable spring loaded gas pressure regulator is present to give a nominal pressure of 1 kPa on Natural Gas. Connect to the Rp  $\frac{1}{2}$  inlet on the underside of the pressure regulator.

### Propane

This cooker is supplied ready for use on Natural gas. A conversion kit for Propane as is supplied with the cooker – see the 'Conversion to Propane Gas' section.

### Pressure Testing

The pressure test point is accessible on the inlet pipe at the rear. Remove the test nipple screw and fit a pressure gauge to the test point. Turn on and light two of the hotplate burners.

For Natural Gas cookers the pressure should be between 0.95kPa and 1.0kPa.

For Propane X cookers the pressure should be 2.54 kPa.

**Fig. 10.11**

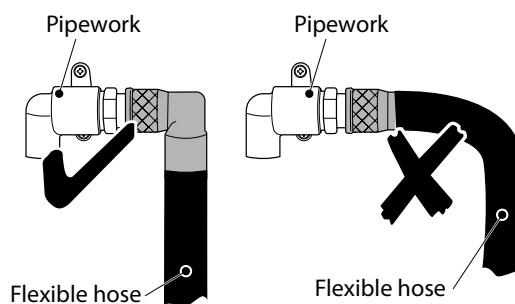

**Fig. 10.12**

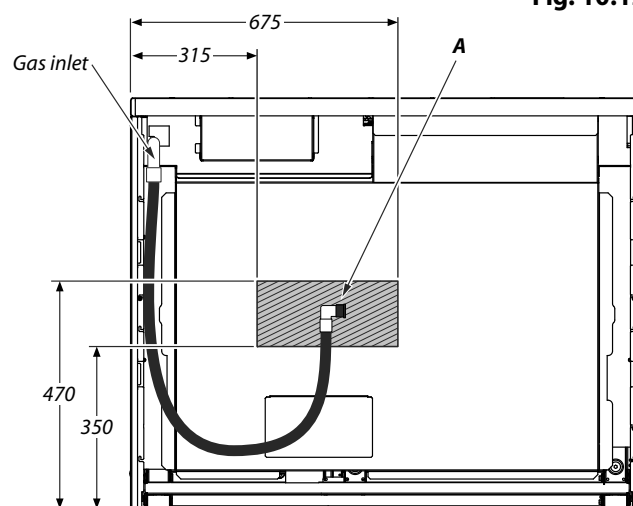

All dimensions in millimetres

## INSTALLATION

Check the appliance is electrically safe and gas sound when you have finished.

### Current Operated Earth Leakage Breakers

The combined use of your cooker and other domestic appliances may casue nuisance tripping, so we recommend that the cooker is protected on an individual RCD (Residual Current Device) or RCBO (Residual Current Breaker with Overload)

**IF IN DOUBT, PLEASE CONTACT A SUITABLY QUALIFIED ELECTRICIAN.**

Fig. 10.13

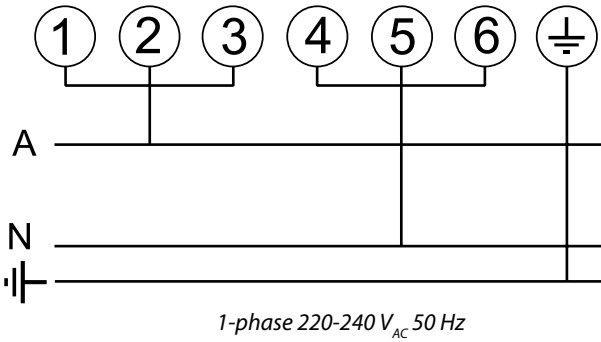
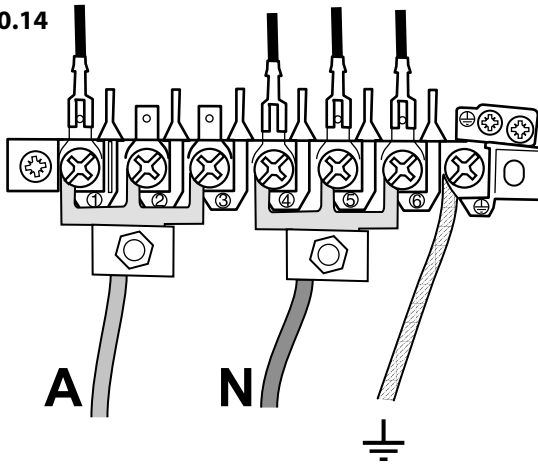

Fig. 10.14



## Electrical Connection

**This appliance must be installed by a qualified electrician to comply with with current AS/NZS 3000 Wiring Rules and regulations in force.**

Make sure that the mains characteristics (voltage, nominal, power, etc.) match the ratings indicated on the cooker data plate.

The cooker is preset for a single-phase earthed electrical connection. It is essential to install a multi-pole circuit breaker that completely disconnects the appliance from the mains, with a minimum contact break distance of 3 mm.

**⚠ WARNING: THIS APPLIANCE MUST BE EARTHED.**

The appliance must be connected to an efficient earthing circuit. If the electricity network is not equipped with an earth connection, then it must be installed separately in compliance with local regulations.

Earthing is a safety measure required by law, and must be performed with particular care by a qualified technician, who must also check that the electricity supply characteristics are correct.

The total electrical load of the appliance is approximately 7.4 kW. The cable size used should be suitable for this load and comply with all local requirements.

Access to the mains terminal is gained by removing the electrical terminal cover box on the back panel. Connect the mains cable to the correct terminals for your electrical supply type (**Fig. 10.13** and **Fig. 10.14**). Check that the links are correctly fitted and that the terminal screws are tight. Secure the mains cable using the cable clamp.

An isolation switch shall be provided and mounted near the cooker, in a readily accessible position, in compliance with AS/NZS 3000 and/or AS/NZS 5601 as applicable for the appliance configuration.



## INSTALLATION

Check the appliance is electrically safe and gas sound when you have finished.

### Fixed Wiring

#### ⚠ Disconnect from the mains supply.

For connection to fixed wiring, i.e. flexible conduit, remove the electrical terminal cover box on the back panel (**Fig. 10.15**).

Fit the conduit box to the cooker using the two M5 screw fittings located at the top of the box. Remove the M4 screw from the base, and fix to the cooker, via the fitting through the back of the conduit box (**Fig. 10.16**).

The conduit box cover is reversible. Fit the reducer plate if required (**Fig. 10.17**). Feed the cable through the conduit box and secure in place with the cable clamp.

Connect the mains cable to the correct terminals for your electrical supply type (**Fig. 10.18**). Check that the links are correctly fitted and that the terminal screws are tight.

Fit the cover to the conduit box.

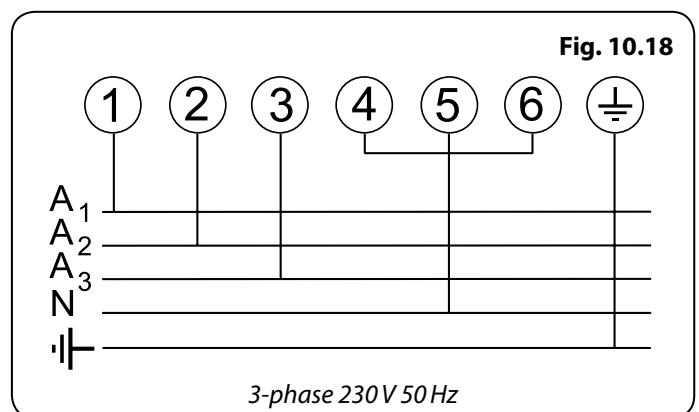
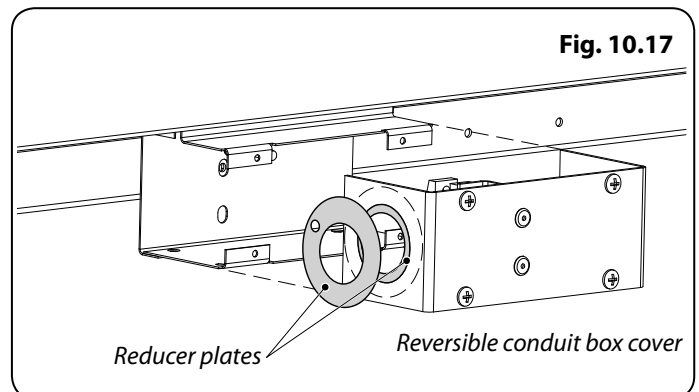
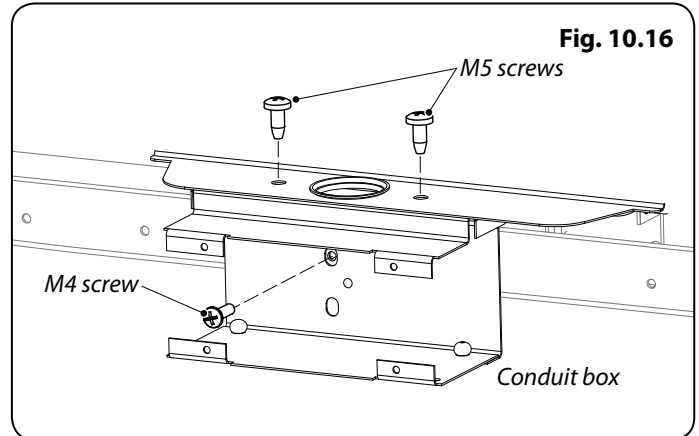
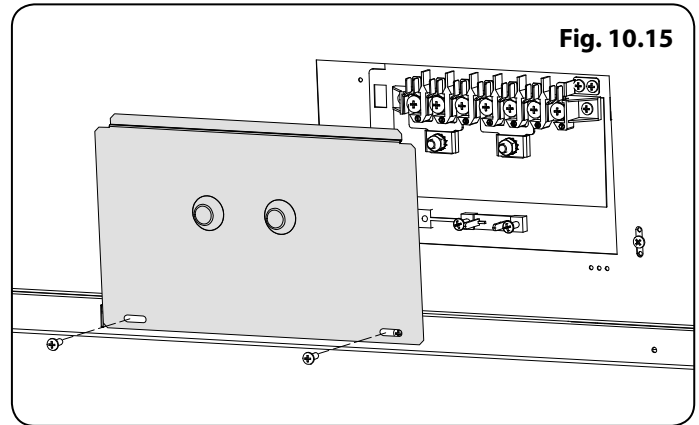

## INSTALLATION

Check the appliance is electrically safe and gas sound when you have finished.

Fig. 10.19

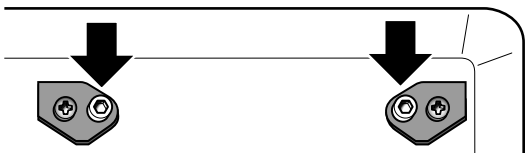

Fig. 10.20

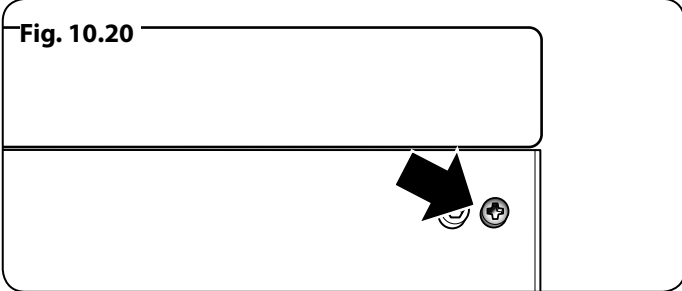

Fig. 10.21

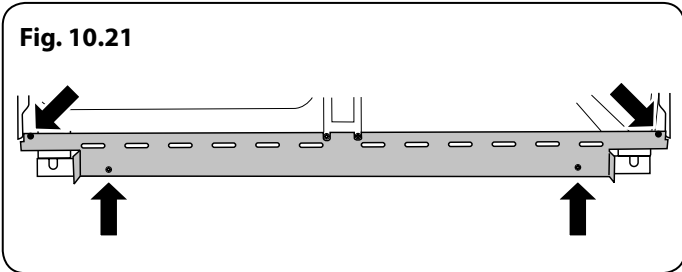
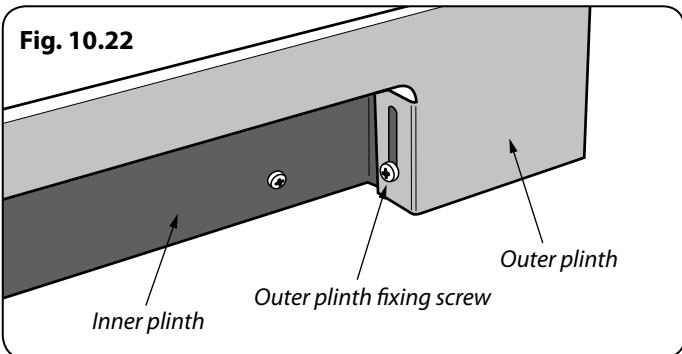

Fig. 10.22



## Final Checks

**NOTE:** The clock must be set before the ovens will work. See 'The Clock' section for instructions on setting the time of day.

## Hotplate Check

Check each burner in turn. There is a Flame Supervision Device (FSD) that stops the flow of gas to the burner if the flame goes out. For each burner, turn the control knob to the solid flame symbol. Press in the control knob. This lets gas through to the burner. Keep holding the knob pressed in and press the igniter button or light with a match. Keep holding the control knob pressed in for about 10 seconds.

If, when you let go of the control knob the burner goes out, the safety device has not held in. Wait one minute then try again this time holding the control pressed in for slightly longer.

## Grill Check

Turn on the grill control and check that the grill heats up.

## Oven Check

Set the clock as described earlier in the instructions, and then turn on the ovens. Check that the oven fan starts to turn and that the ovens start to heat up.

**NOTE:** The oven light bulb is not included in the guarantee.

Turn off the oven.

## Final Fitting

### Fitting the Handles and Handrail

Remove the 4 mm Allen screws from the doors (Fig. 10.19). Fit the door handles and secure using the 4 mm screws.

**▲ The handles should be above the fixings.**

Remove the 4 mm Allen screws from the top corners of the fascia (Fig. 10.20). Fit the handrail in position and secure using the 4 mm screws.

### Fitting the Plinth

Fit the inner plinth to the bottom front of the cooker using the 4 screws provided (Fig. 10.21).

Fit the outer plinth (2 screws, 1 each end) to the inner plinth.

The height of the outer plinth can be adjusted by sliding it up or down via the slotted hole (Fig. 10.22).

### Fitting the Splashback

Position the splashback on the rear of the hotplate and secure with the screws supplied.

## Customer Care

Installer: Please complete your details in this guide, inform the user how to operate the cooker and hand over the instructions.

**WARNING – SERVICING TO BE CARRIED OUT ONLY BY AN AUTHORISED PERSON**  
Disconnect from electricity and gas before servicing. Check appliance is safe when you have finished.

## 11. Conversion to LP Gas

### Conversion from Natural Gas (1.0 kPa) to LPG X Propane (2.54 kPa)

- ⚠** A suitably competent person must perform the conversion. After conversion the installation must comply with the relevant regulations and also the local electricity supply company requirements. Read the instructions before converting this appliance.
- ⚠** Failure to convert the appliance correctly could invalidate any warranty or liability claims and lead to prosecution.
- ⚠** When servicing or replacing gas-carrying components disconnect from the gas supply before starting operation. Check the appliance is gas sound after completion.
- ⚠** DO NOT use reconditioned or unauthorised gas controls.
- ⚠** Disconnect from the electricity and gas supply before servicing.
- ⚠** Before electrical reconnection, check that the appliance is electrically safe.

### Injectors

Remove the burner caps and heads. Remove the old jets (Fig. 11.1). Fit the new jets (see the 'Technical Data' section at the back of this book for the correct jets). Reassemble in reverse order.

### Tap Adjustment

#### Removing the Control Panel *(depending on model)*

Remove the handrail. Now remove the 2 cross-headed screws hidden behind the handrail end brackets (Fig. 11.2).

Pull off all the control knobs and remove the fixing screws underneath the control panel.

Lift the control panel and pull forwards, taking care not to damage or strain the wiring.

#### Bypass Screw Adjustment

Turn the bypass screw on each control clockwise to the stop (Fig. 11.3). Refit the control panel.

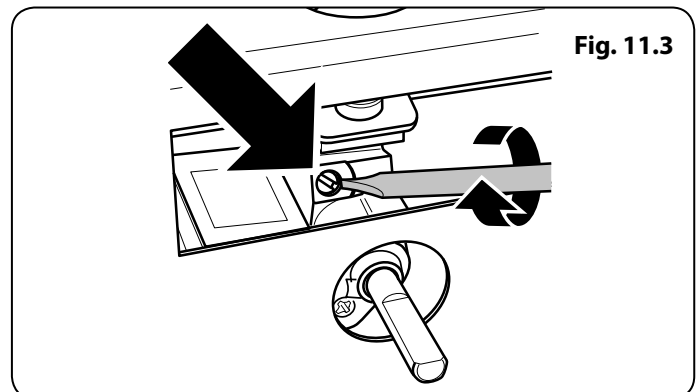
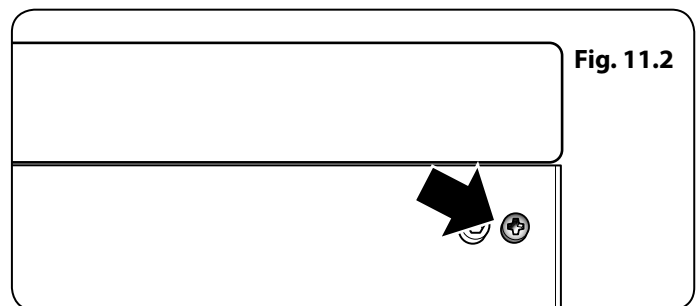
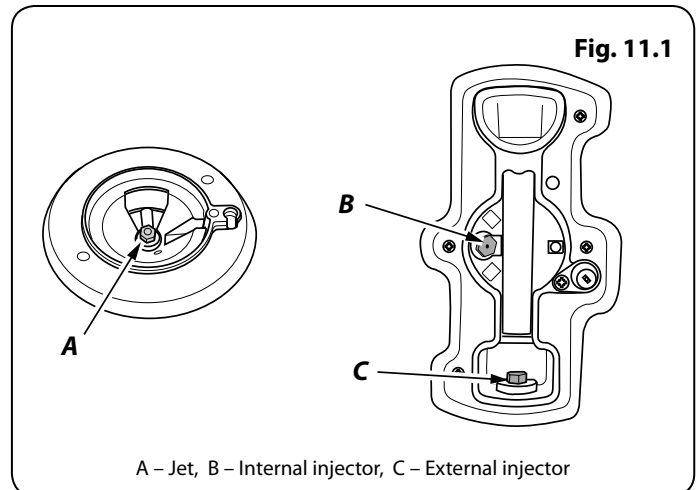

**WARNING – SERVICING TO BE CARRIED OUT ONLY BY AN AUTHORISED PERSON**  
Disconnect from electricity and gas before servicing. Check appliance is safe when you have finished.

**Fig. 11.4**

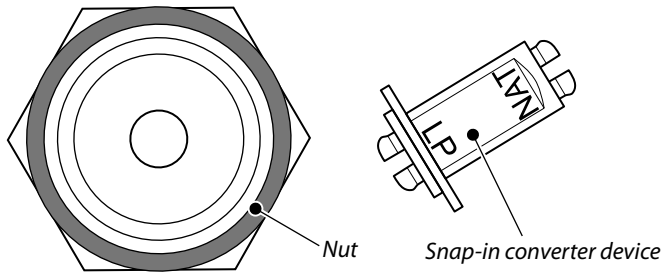

## Set the Governor

Unscrew the governor's brass top. In the base of the brass top is a plastic snap-in converter device (**Fig. 11.4**). To convert the governor, snap the device out of the top and refit it the other way round. The snap-in converter device is marked to show the gas for which it is set (**Fig. 11.5**).

Make sure the device is secure in the top cap and refit the cap to the governor.

## Pressure Testing

The pressure test point is accessible on the inlet pipe at the rear. Remove the test nipple screw and fit a pressure gauge to the test point. Turn on and light two of the hotplate burners.

For Propane X cookers the pressure should be 2.54 kPa.

- ▲ **Check the appliance is gas sound.**
- ▲ **Check operation of all the burners.**

## Affix Label

Stick the appropriate gas label over the natural gas part of the appliance data label.

**Fig. 11.5**

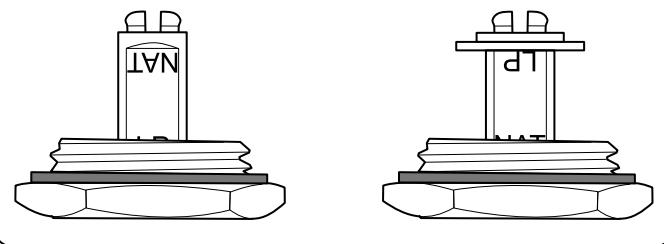

**WARNING – SERVICING TO BE CARRIED OUT ONLY BY AN AUTHORISED PERSON**  
Disconnect from electricity before servicing. Check appliance is safe when you have finished.

## 12. Servicing

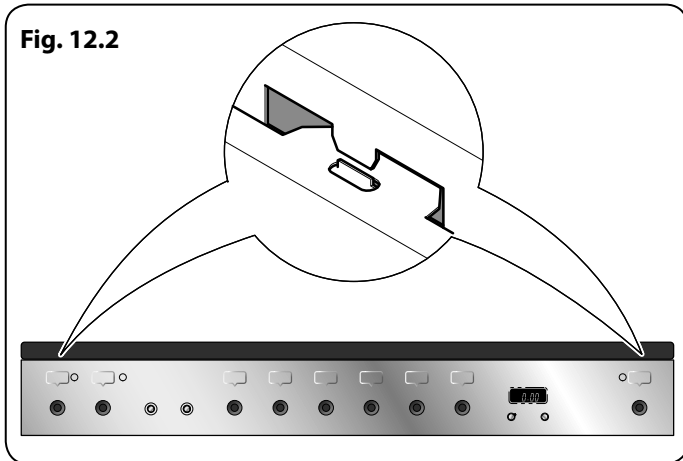
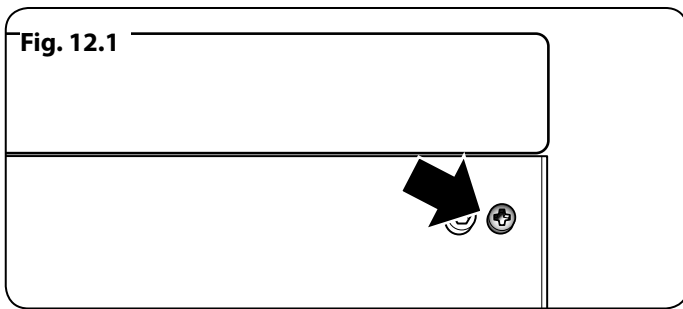

- ⚠ BEFORE SERVICING ANY GAS CARRYING COMPONENTS TURN OFF THE GAS SUPPLY**
- ⚠ Check the appliance is gas sound after completion of service. When checking for gas leaks do not use washing up liquid – this can corrode. Use a product specifically manufactured for leak detection.**
- ⚠ Do not use reconditioned or unauthorised gas controls.**
- ⚠ Disconnect from the electricity supply before servicing, particularly before removing any of the following: control panel, side panels, hotplate tray or any electrical components or covers.**
- ⚠ Before electrical reconnection, check that the appliance is electrically safe.**

### 1. Panels

#### 1.1 To Remove the Control Panel

- ⚠ DISCONNECT FROM THE ELECTRICITY SUPPLY.**

##### Classic – Removing the Control Panel

Remove the handrail. Now remove the 2 cross-headed screws hidden behind the handrail end brackets (**Fig. 12.1**).

Pull off all the control knobs and remove the fixing screws underneath the control panel.

Lift the control panel and pull forwards, taking care not to damage or strain the wiring.

##### Professional + – Removing the Control Panel

Pull off all the control knobs.

Open the grill and right-hand oven doors and remove the 4 fixing screws underneath the control panel.

The control panel should drop down slightly. It is held at the top by 2 holes in the top edge, 1 at each end, that locate on tags on the inner panel (**Fig. 12.2**). Clear the control panel holes from the inner panel and pull the control panel forward.

Disconnect the wiring from the rear.

Reassemble in the reverse order. When replacing the leads refer to the wiring diagram. Check the operation of the timer.

#### 1.2 To Remove the Side Panels

- ⚠ DISCONNECT FROM THE ELECTRICITY SUPPLY.**

Remove the control panel (see **1.1**). Pull the cooker forward. Remove the 4 retaining screws for each panel (1 at the front base, 1 on the top and 2 at the rear).

Reassemble in the reverse order.

**WARNING – SERVICING TO BE CARRIED OUT ONLY BY AN AUTHORISED PERSON**  
**Disconnect from electricity before servicing. Check appliance is safe when you have finished.**

**Fig. 12.3**

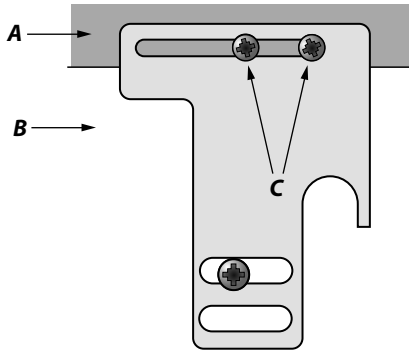

*A – Flue grill, B – Cooker backsheet, C – Earthing/fixing screws*

**Fig. 12.4**

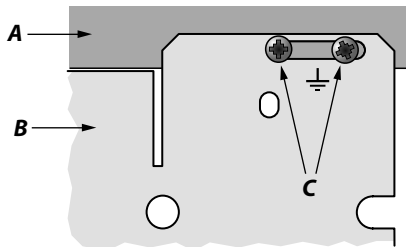

*A – Flue grill, B – Cooker backsheet, C – Earthing/fixing screws*

## 2. Hotplate

**⚠ BEFORE SERVICING ANY GAS CARRYING COMPONENTS, TURN OFF THE GAS SUPPLY.**

### 2.1 To Remove the Hotplate

Pull the cooker forward to gain access to the rear.

#### Left-hand tray

From the rear remove the screws securing the flue grill to the hotplate tray. Remove pan supports, burner heads and caps. Remove the 4 screws and washers holding the hotplate tray to the frame. Raise the front of the hotplate then withdraw.

#### Right-hand tray

From the rear remove the screws securing the flue grill to the hotplate tray. If the left-hand hotplate has not been removed, slacken the screws holding the left-hand tray. Remove pan support, burner head, caps and trim rings. Remove the screws holding the wok burner to the hotplate. Remove the 2 screws and washers holding the right-hand tray to the frame.

Press the wok burner down slightly and, taking care not to damage the wok burner electrode, slide the tray about 30 mm to right to clear the locating brackets on the right-hand side. Lift tray slightly at the front and taking care not to stress the warmer/lead junction, disconnect the leads to the warmer neon and separate the leads at the piggybacks. Withdraw the hotplate.

Reassemble in the reverse order ensuring that the leads are reconnected. When replacing the right-hand hotplate take care not to damage the ignition electrode of the wok burner.

It is important that the rear fixing screws are refitted as they form part of the cooker earthing.

On some models there is a separate plate (**Fig. 12.3**). On others it is a tag on the cooker backsheet (**Fig. 12.4**).

It is important that the tag is on the outside and that both fixing screws are fitted.

Check for correct burner operation.

### 2.2 To Replace the Hotplate Control Taps

**⚠ DISCONNECT FROM THE ELECTRICITY SUPPLY.**

**⚠ BEFORE SERVICING ANY GAS CARRYING COMPONENTS, TURN OFF THE GAS SUPPLY.**

Remove the control panel and hotplate (see **1.1** & **2.1**). Unplug the FSD lead from the rear of the tap. Undo the compression fitting at the rear of the tap and remove the fixings that secure the tap to the gas rail. Disconnect the ignition switch wiring.

Remove the tap. Remove and discard the gasket seal. Fit the new gasket seal to the replacement tap. Reassemble in reverse order. Check that the appliance is gas sound. Verify the hotplate ignition.

### 2.3 To Change a Hotplate Burner Injector

Remove the burner cap and head. Remove the old injector.

Fit the new injector. Reassemble in the reverse order. Check

**WARNING – SERVICING TO BE CARRIED OUT ONLY BY AN AUTHORISED PERSON**  
**Disconnect from electricity before servicing. Check appliance is safe when you have finished.**

the appliance is gas sound.

#### **2.4 To Replace a Hotplate Burner Electrode**

##### **⚠ DISCONNECT FROM THE ELECTRICITY SUPPLY.**

Lift off pan supports and remove the burner cap. Remove the screw holding the electrode. Pull the electrode vertically up sufficiently to grip the lead between thumb and forefinger.

Pull off the electrode, but keep hold of the lead. Fit the new electrode to the lead. Fix the electrode in the burner with screw. Replace the burner cap.

Check the burner ignition. Replace the pan supports.

#### **2.5 To Replace a Hotplate Burner**

##### **⚠ DISCONNECT FROM THE ELECTRICITY SUPPLY.**

Remove the hotplate tray (see 2.1). The burners (except the right-hand wok burner) are mounted on support struts. For these burners, disconnect the burner feed pipes at the burner. Remove the screws at the front and rear holding the support struts. Lift the strut and burners clear. The burners are fixed to the support struts with 2 screws. Remove the appropriate burner and fit the new one.

Reassemble in reverse order. Check that the burner operation is satisfactory.

##### **Right-hand Wok Burner**

Disconnect the burner feed pipes at the burner.

Fit the new one and reassemble in reverse order. Check that the burner operation is satisfactory.

#### **2.6 To Change a Hotplate Burner Thermocouple**

##### **⚠ DISCONNECT FROM THE ELECTRICITY SUPPLY.**

Remove the control panel and hotplate (see 1.1 & 2.1).

Unplug the FSD lead from the rear of the tap.

The thermocouple sits in a hole that has a slot at one side. Ensure that the thermocouple is cool. Turn the thermocouple so that the earth lead (no sleeve) is in line with the slot. Lift the thermocouple clear of the hole.

Reassemble in reverse order.

### **3. Controls**

#### **3.1. To Replace the Ignition or Light Switch**

##### **⚠ DISCONNECT FROM THE ELECTRICITY SUPPLY.**

Remove the control panel (see 1.1).

Note: The old switch may be destroyed during removal. Remove the old switch from its bezel by gripping the switch body behind the control panel and twisting sharply. Remove the switch bezel by folding back the locking wings and pushing forward.

To fit the new bezel to the control panel: first line up the raised key on its body with the cut-out in the control panel and push it in from the front.

Assemble the new switch to the bezel by lining up the key

sections and pushing home. Fit the new button by pushing in from the front.

Replace the control panel in the reverse order and test for correct operation.

#### **3.2 To Replace the Clock**

##### **⚠ DISCONNECT FROM THE ELECTRICITY SUPPLY.**

Remove the control panel (see 1.1). Pull off the timer control buttons.

Undo the timer fixing screws and remove the timer/mounting bracket assembly from the control panel.

Remove the timer from its mounting bracket by depressing the plastic lugs on the timer case, and at the same time pulling the unit forward.

Reassemble in reverse order. When replacing the leads, refer to the wiring diagram. Check the operation of the timer.

#### **3.3 To Change the Ignition Generator**

##### **⚠ DISCONNECT FROM THE ELECTRICITY SUPPLY.**

Pull the cooker forwards to gain access to the cover box at the rear of the cooker. Remove the screws securing the cover and lift clear. Pull off all the leads to the generator noting their positions. Slacken the 2 screws holding generator to cooker and remove the generator.

Fit the new generator to the cooker and replace the leads. Refer to the wiring diagram and reassemble in reverse order. Check ignition performance.

### **4. Grill**

#### **4.1 To Replace the Grill Controller**

##### **⚠ DISCONNECT FROM THE ELECTRICITY SUPPLY.**

Remove the control panel and hotplate (see 1.1 & 2.1). Disconnect the wiring from controller. Remove the 2 screws holding the controller to the mounting panel.

Fit the new controller and reassemble in the reverse order. Check for correct operation.

#### **4.2 To Replace the Grill Element**

##### **⚠ DISCONNECT FROM THE ELECTRICITY SUPPLY.**

Remove the grill pan from the grill chamber. From inside the grill compartment, undo the 2 screws and washers and remove the enamelled front shield from the grill roof. Remove 2 screws and washers securing the grill element front support. Remove the screws from the grill elements.

Carefully lift the elements out and disconnect the leads from the element terminals, noting their position.

If it is not possible to disconnect the leads in this way, pull cooker forwards to gain access to the rear.

Remove the screws securing the electric cover to the back sheet, and then remove cover and disconnect the terminals from the rear.

Fit the new elements and reassemble in reverse order. Check the operation of the grill.

**WARNING – SERVICING TO BE CARRIED OUT ONLY BY AN AUTHORISED PERSON**  
**Disconnect from electricity before servicing. Check appliance is safe when you have finished.**

**Fig. 12.5**

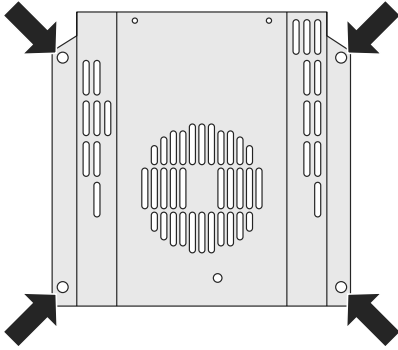

## 5. Ovens

### 5.1 To Replace an Oven Thermostat

#### **⚠ DISCONNECT FROM THE ELECTRICITY SUPPLY.**

Remove the control panel and hotplate (see 1.1 & 2.1). Open the oven door and remove the oven furniture.

For the right-hand oven, remove the thermostat phial cover (2 screws). Unclip the thermostat phial from the clips in the oven back. For the left-hand oven, pull cooker forward to gain access to the cover box at the rear of the cooker. Remove the 4 screws securing the cover and lift clear.

Feed the thermostat capillary out of the oven. Disconnect the wiring from the thermostat. Remove 2 screws holding thermostat to mounting panel. Fit new thermostat and reassemble in the reverse order. Make sure that the phial is clipped to the oven back with the phial centrally positioned between the clips.

Check the operation of the thermostat.

### 5.2 To Remove an Oven Inner Back

Open the oven door. Remove the screws and washers securing the inner back to the back of the oven (Fig. 12.5).

Carefully lift away the inner back.

Reassemble in reverse order, making sure that you fully tighten the 4 screws and washers.

### 5.3 To Change the Fan in an Oven

#### **⚠ DISCONNECT FROM THE ELECTRICITY SUPPLY.**

Pull the cooker forward to gain access to the rear. Remove the screws securing the electric cover to the back sheet and remove the cover. Disconnect the 3 terminals connected to the fan, noting their position.

Remove the oven inner back (see 5.2). Hold the fan blade and remove the centre nut (left-hand thread), 2 brass washers, fan blade and circlip. Unscrew the fan retaining nuts and washers (3 off each) and lift the fan away from the rear of the cooker.

Fit the new fan and reassemble in reverse order. Check the operation of the oven.

### 5.4 To Remove an Oven Element Thermal Cut-out

#### **⚠ DISCONNECT FROM THE ELECTRICITY SUPPLY.**

Pull the cooker forwards to gain access to the cover box. Undo the cover screws and lift clear. The cut-out is located on the earth plate beside the oven element connections. Disconnect the cut-out wiring. Undo the fixings that secure the cut-out to the earth plate and remove.

Fit the replacement control and re-assemble in reverse order.



**WARNING – SERVICING TO BE CARRIED OUT ONLY BY AN AUTHORISED PERSON**  
**Disconnect from electricity before servicing. Check appliance is safe when you have finished.**

### 5.5 To Remove an Oven Element

#### **⚠ DISCONNECT FROM THE ELECTRICITY SUPPLY.**

Remove the oven inner back (see 5.2).

Remove the 2 screws from the top of the element and the 1 from the bottom of the element (**Fig. 12.6**).

Carefully lift the element out, disconnecting the terminals connected to the element (noting their positions).

If it is not possible to disconnect the leads in this way, pull the cooker forward to gain access to the rear, remove the screws securing the electric cover to the back sheet, remove the cover and disconnect the terminals from the rear.

Fit the new element and reassemble in reverse order. Check the operation of the oven.

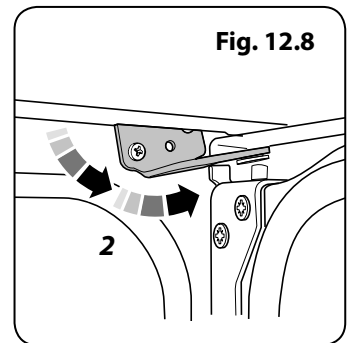
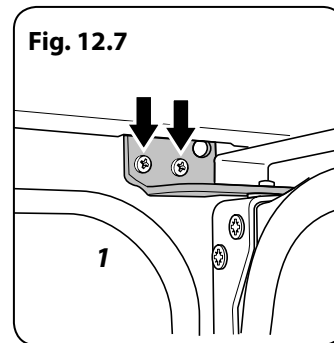
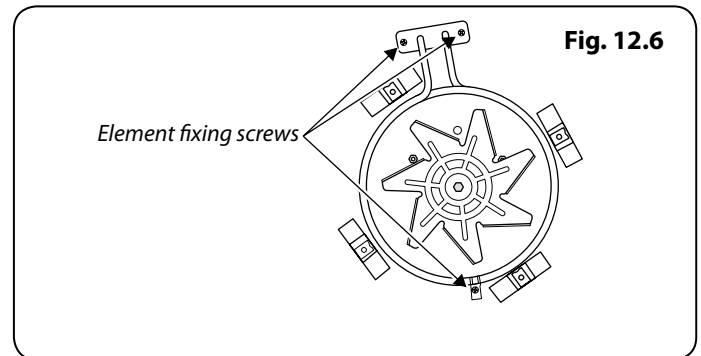

## 6. Doors

### 6.1 To Remove the Grill Door

Remove the left-hand side panel (see 1.2). Remove the plinth (4 screws) and the central vertical cover (5 screws). Remove the 2 countersunk screws (1 each side) securing the grill hinge arms to the front of the grill chamber.

Note: The arms are spring tensioned. Carefully remove the grill door. Retain the gaskets.

Reassemble in reverse order, making sure that the gasket is fitted between the hinge arm and the front of the grill chamber.

### 6.2 To Replace an Oven Door

Open the oven door. Support the door and loosen the 2 screws securing the upper hinge and gasket to the cooker front (**Fig. 12.7**).

#### **⚠ THE DOOR IS HEAVY, SO TAKE CARE.**

Support the door and remove the screw nearest the hinge pin (**Fig. 12.8**). Swing the hinge up and away from the door hinge pin. Lift the door away from the lower hinge and remove. Reassemble in reverse order.

### 6.3 To Adjust an Oven Door Angle

The bottom hinge of either oven door can be adjusted to alter the angle of the door (**Fig. 12.9**). Loosen the bottom hinge fixing screws and use the notch and a flat bladed screwdriver to move the position of the hinge to set the hinge position (**Fig. 12.10**).

Retighten the hinge screws.

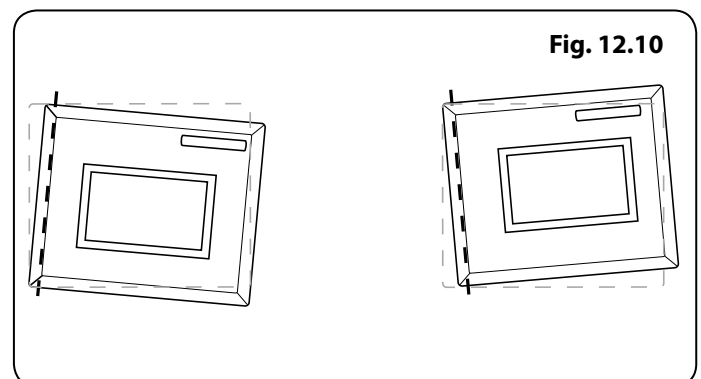
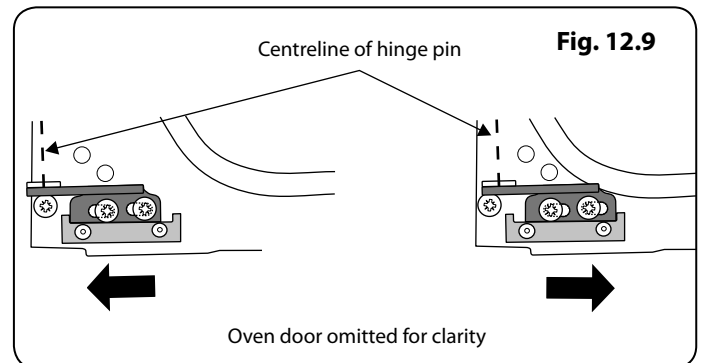

**WARNING – SERVICING TO BE CARRIED OUT ONLY BY AN AUTHORISED PERSON**  
**Disconnect from electricity before servicing. Check appliance is safe when you have finished.**

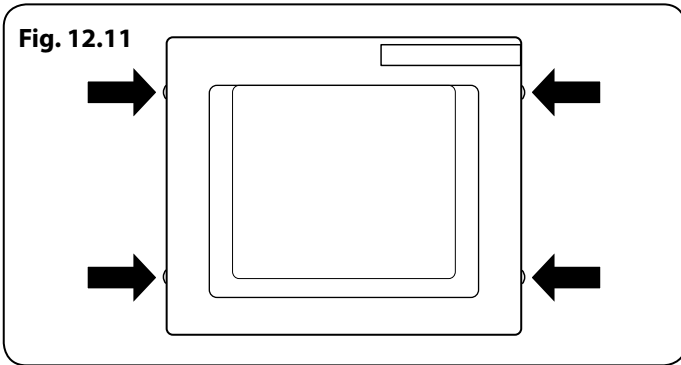

#### 6.4 To Replace an Oven Door Outer Panel

Move the cooker forwards to gain access to the sides.

Open the oven door slightly and remove the 4 front panel fixing screws from the door sides (2 each side), (Fig. 12.11). Carefully lift off the outer door panel.

Remove the door handle from the panel by unscrewing the 2 retaining nuts. Fit the door handle to the new panel. Fit the panel to the door. Reassemble in the reverse order.

#### 6.5 To Change the Oven Door Latch

Remove the outer door panel (see 6.4). Remove screws 'B', which hold the latch assembly to the inner door panel (Fig. 12.12). Fit the new catch and reassemble in reverse order. Check the door operation.

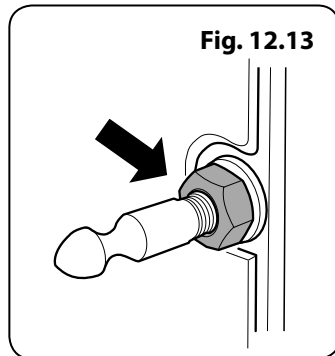
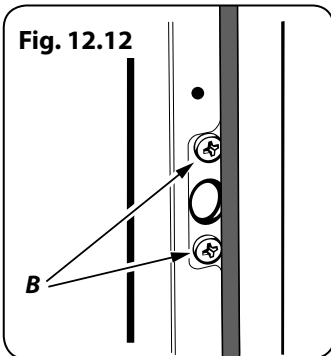

#### 6.6 To Adjust an Oven Door Catch Keep

Open the oven door, slacken off the locknut at the base of the keep, and screw in or out as required until the required fit is obtained. Retighten the locking nut (Fig. 12.13).

#### 6.7 To Change an Oven Door Seal

Open the oven door. The seal is held in place by small hooks on the rear face. At the corner, pull the seal diagonally away from the door centre until that hook is released (Fig. 12.14). Proceed to the next hook and release it in a similar way, and so on. Use force if the hooks are stiff, as the old seal will be discarded.

When fitting the new seal, position the seal join at the bottom. Hook the new seal in one of the corner holes of the door, and proceed round the door, snapping in each hook in turn.

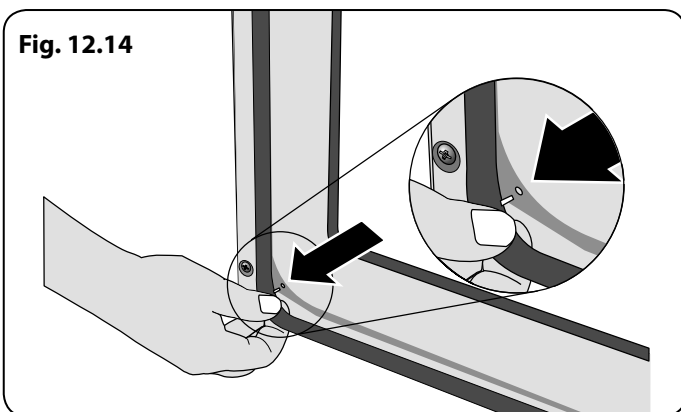

#### 6.8 Oven Door Glass

The glass on the oven doors is not replaceable.

# 13. Circuit Diagram

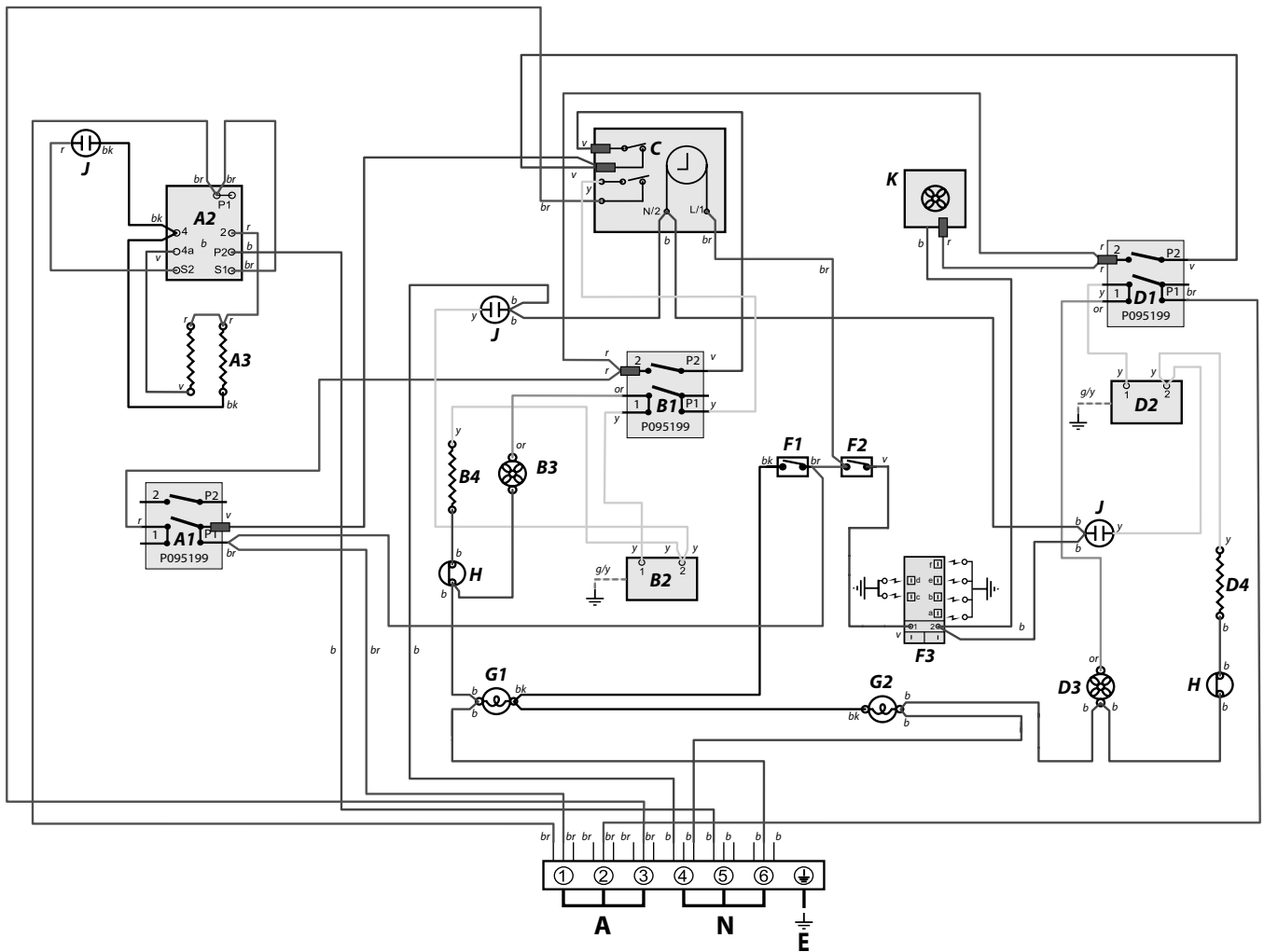

### Key

The connections shown in the circuit diagram are for single-phase. The ratings are for 230V 50Hz.

Code	Description
<b>A1</b>	Grill front switch
<b>A2</b>	Grill energy control
<b>A3</b>	Grill elements
<b>B1</b>	Left hand oven front switch
<b>B2</b>	Left hand oven front thermostat
<b>B3</b>	Left hand oven fan
<b>B4</b>	Left hand oven fan element
<b>C</b>	Clock
<b>D1</b>	Right hand oven front switch
<b>D2</b>	Right hand oven thermostat
<b>D3</b>	Right hand oven fan
<b>D4</b>	Right hand oven fan element

Code	Description
<b>F1</b>	Oven light switch
<b>F2</b>	Ignition switch
<b>F3</b>	Ignition spark generator
<b>G1</b>	Left hand oven light
<b>G2</b>	Right hand oven light
<b>H</b>	Thermal
<b>J</b>	Neon
<b>K</b>	Cooling fan

Code	Colour
<b>b</b>	Blue
<b>br</b>	Brown
<b>bk</b>	Black
<b>or</b>	Orange
<b>r</b>	Red
<b>v</b>	Violet
<b>w</b>	White
<b>y</b>	Yellow
<b>g/y</b>	Green/yellow

## 14. Technical Data

This cooker is designed for use on Natural Gas, although a conversion for LP (LPG X Propane (2.54 kPa)) gas is packed with the cooker.

**INSTALLER:** Please leave these instructions with the user.

**DATA BADGE LOCATION:** Cooker back, serial number repeater badge below oven door opening.

**Country of destination:** Australia.

### Connections

Gas (Rp ½ at rear right-hand side)		Electric
Natural gas	1 kPa	230V 50Hz
Propane	2.54 kPa	

See the appliance badge for test pressures.

### Dimensions Refer to 'Positioning the Cooker'.

Overall height	minimum 905 mm	maximum 930 mm
Overall width	1092 mm	
Overall depth	608 mm excluding handles; 670 mm including handles	
Minimum space above the hotplate	650 mm	

### Ratings

Hotplate	Bypass Screw*	Natural Gas 1 kPa		LP Gas 2.54 kPa	
		Input	Injector	Input	Injector
Wok burner	55	15.2 MJh <sup>-1</sup>	Internal 88	15.0 MJh <sup>-1</sup>	Internal 57
			External 168		External 98
Large burner	41	12.3 MJh <sup>-1</sup>	165	12.0 MJh <sup>-1</sup>	89
Medium burner	33	6.2 MJh <sup>-1</sup>	115	6.2 MJh <sup>-1</sup>	67
Small burner	25	3.7 MJh <sup>-1</sup>	92	3.3 MJh <sup>-1</sup>	48

\* The valves in this cooker are fitted with adjustable bypass screws. The cooker is supplied with the bypass screws set for Natural gas. For LPG conversion the bypass screws must be screwed all the way down.

### Oven Efficiency

Ovens	Left-hand Oven	Right-hand Oven
	Forced Air Convection	Forced Air Convection
Maximum power output @ 230V 50Hz	2.5 kW	2.5 kW
Energy efficiency class on a scale of A (more efficient) to G (less efficient)	A	A
Energy consumption based on standard load	0.90 kWh	0.90 kWh
Usable volume (litres)	79	79
Size	Large	Large
Time to cook standard load	38 minutes	38 minutes
Surface area of the grid	1400 cm <sup>2</sup>	1400 cm <sup>2</sup>

Grill	2.3 kW
Warmer	160W

**Maximum total electrical load at 230 V** (approximate total including oven lights, oven fan, etc.): 7.43 kW.



## NOTE

---

## NOTE

---

## NOTE

---

Clarence Street, Royal Leamington Spa,  
Warwickshire, CV31 2AD, England.  
Tel: +44 (0) 1926 457628  
E-mail: [consumers@falconappliances.co.uk](mailto:consumers@falconappliances.co.uk)

